

Preparatory
Problems

41st
International
Chemistry
Olympiad
UK, 2009



UNIVERSITY OF
CAMBRIDGE



UNIVERSITY OF
OXFORD

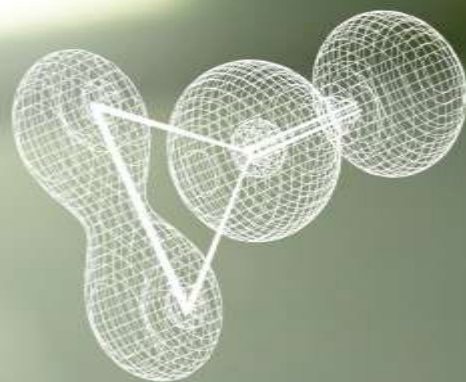

Problem Authors

Stephen Ashworth University of East Anglia

Jonathan Burton University of Oxford

Jon Dilworth University of Oxford

Nicholas Green University of Oxford

Philip Mountford University of Oxford

William Nolan University of Cambridge

Jeremy Rawson University of Cambridge

Kathryn Scott University of Oxford

Malcolm Seddon University of East Anglia

Simon Titmuss University of Oxford

Claire Vallance University of Oxford

Peter Wothers University of Cambridge

Fields of Advanced Difficulty

Theoretical

Kinetics: integrated first-order rate equation; analysis of moderately complex reactions mechanisms using the steady state approximation, the use of the Arrhenius equation, simple collision theory

Thermodynamics: electrochemical cells, the relationship between equilibrium constants, electromotive force and standard Gibbs energy, the variation of the equilibrium constant with temperature

Quantum mechanics: calculation of orbital and spin angular momentum, calculation of the magnetic moment using the spin-only formula

Spectroscopy: interpretation of relatively simple ^{13}C and ^1H NMR spectra; chemical shifts, multiplicities, coupling constants and integrals

Mass spectrometry: molecular ions and basic fragmentation

Theoretical problems

Problem 1 *Dating moon rock*

The age of rocks collected from the moon on the Apollo 16 mission has been determined from the $^{87}\text{Rb} / ^{86}\text{Sr}$ and $^{87}\text{Sr} / ^{86}\text{Sr}$ ratios of different minerals found in the sample.

Mineral	$^{87}\text{Rb} / ^{86}\text{Sr}$	$^{87}\text{Sr} / ^{86}\text{Sr}$
A (Plagioclase)	0.004	0.699
B (Quintessence)	0.180	0.709

- a) ^{87}Rb is a β^- emitter, write down the equation of nuclear decay. The half-life for this decay is 4.8×10^{10} years.
- b) Calculate the age of the rock. You can assume that the initial $^{87}\text{Sr} / ^{86}\text{Sr}$ is the same in **A** and **B** and that ^{87}Sr and ^{86}Sr are stable.

Problem 2 *Snorkelling*

The pressure of a gas may be thought of as the force the gas exerts per unit area on the walls of its container, or on an imaginary surface of unit area placed somewhere within the gas. The force arises from collisions between the particles in the gas and the surface. In an ideal gas, the collision frequency (number of collisions per second) with a surface of unit area is given by:

$$Z_{\text{surface}} = \frac{p}{\sqrt{2\pi m k_{\text{B}} T}}$$

Where p is the pressure and T the temperature of the gas, m is the mass of the gas particles, and k_{B} is the Boltzmann's constant ($k_{\text{B}} = 1.38 \times 10^{-23} \text{ J K}^{-1}$).

At sea level, atmospheric pressure is generally around 101.3 kPa, and the average temperature on a typical British summer day is 15°C.

- a) Using the approximation that air consists of 79% nitrogen and 21% oxygen, calculate the weighted average mass of a molecule in the air.

- b) Human lungs have a surface area of approximately 75 m^2 . An average human breath takes around 5 seconds. Estimate the number of collisions with the surface of the lungs during a single breath on a typical British summer day. You should assume that the pressure in the lungs remains constant at atmospheric pressure; this is a reasonable approximation, as the pressure in the lungs changes by less than 1% during each respiratory cycle.

The human lungs can operate against a pressure differential of up to one twentieth of atmospheric pressure. If a diver uses a snorkel for breathing, we can use this fact to determine how far below water the surface of the water she can swim.

The pressure experienced by the diver a distance d below the surface of the water is determined by the force per unit area exerted by the mass of water above her. The force exerted by gravity on a mass m is $F = mg$, where $g = 9.8 \text{ m s}^{-2}$ is the acceleration due to gravity.

- c) Write down an expression for the mass of a volume of water with cross sectional area A and depth d .
- d) Derive an expression for the force exerted on the diver by the volume of water in (c), and hence an expression for the difference in pressure she experiences at depth d relative to the pressure at the water's surface.
- e) Calculate the maximum depth the diver can swim below the water surface, while still breathing successfully through a snorkel.

Problem 3 *Ideal and not-so-ideal gases*

The force a gas exerts on the walls of its container arises from collisions between the particles in the gas and the surface. In a single collision, the magnitude of the impulsive of the force exerted on the surface is equal to the change in the momentum normal to the surface, $m\Delta v$. The force on the surface is then the impulse, multiplied by the rate at which the particles collide with the surface.

Since the motion of particles within a gas is random, the number of collisions occurring per unit time is a constant for a gas at constant temperature.

The temperature of a gas reflects the distribution of particle velocities within the gas. For a given gas, the particle speeds will be higher, on average, at higher temperatures.

- a) Given the above information, and assuming the gas is initially at room temperature and atmospheric pressure, consider how carrying out the following actions would be likely to affect the pressure. Would the pressure double, halve, increase slightly, decrease slightly, or remain unchanged?
- Doubling the number of particles in the gas.
 - Doubling the volume of the container in which the gas is confined.
 - Doubling the mass of the particles in the gas (assume that the particle velocities remain constant).
 - Increasing the temperature by 10°C .

The ideal gas model assumes that there are no interactions between gas particles. Particles in a real gas do interact through a range of forces such as dipole–dipole forces, dipole–induced–dipole forces, and van der Waals interactions (induced–dipole–induced–dipole forces). A typical curve showing the potential energy of interaction between two particles is shown right:

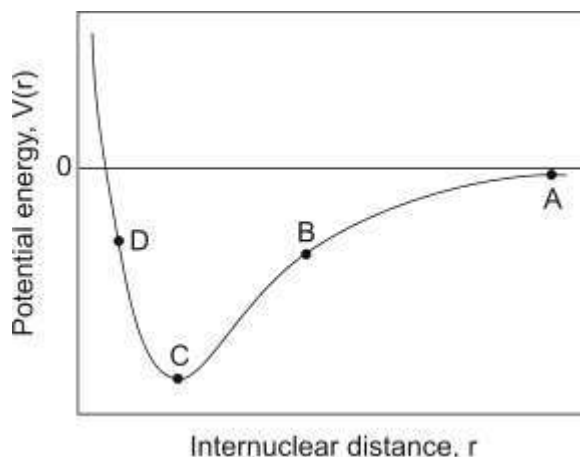

The force between two particles in a gas at a given separation r may be calculated from the gradient of the potential energy curve i.e. $F = -dV / dr$.

- b) What is the force at the four points marked **A**, **B**, **C** and **D** on the figure?
(attractive / repulsive / approximately zero)

The deviation from non-ideality in a gas is often quantified in terms of the compression ratio, Z .

$$Z = \frac{V_m}{V_m^0}$$

where V_m is the molar volume of the (real) gas, and V_m^0 is the molar volume of an ideal gas under the same conditions of temperature, pressure etc.

- c) Match the following values of Z with the dominant type of interaction in the gas.

[$Z = 1$]

[$Z < 1$]

[$Z > 1$]

Attractive forces dominate

Repulsive forces dominate

No intermolecular forces, ideal gas behaviour

- d) The compression ratio is pressure dependent. Consider the average separation between particles in a gas at different pressures (ranging from extremely low pressure to extremely high pressure), and the regions of the intermolecular potential that these separations correspond to. Sketch the way in which you think the compression ratio will vary with pressure on the set of axes below. [Note: do not worry about the actual numerical values of Z ; the general shape of the pressure dependence curve is all that is required.]

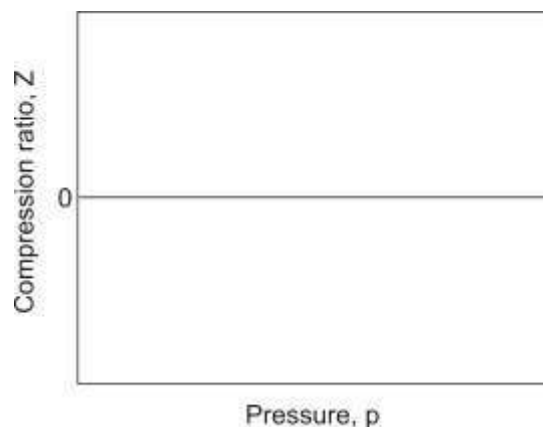

Problem 4 Coal gasification

In the process of coal gasification coal is converted into a combustible mixture of carbon monoxide and hydrogen, called coal gas

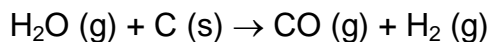

- a) Calculate the standard enthalpy change for this reaction from the following chemical equations and standard enthalpy changes

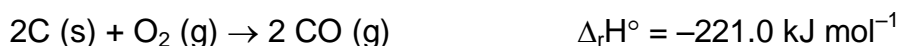

The coal gas can be used as a fuel :

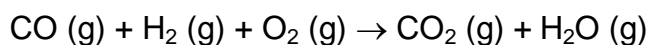

- b) Given the additional information, calculate the enthalpy change for this combustion

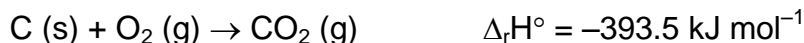

Coal gas can also undergo the process of *methanation*.

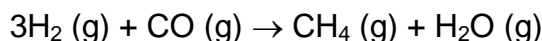

- c) Determine the standard enthalpy change for the methanation reaction using the additional data.

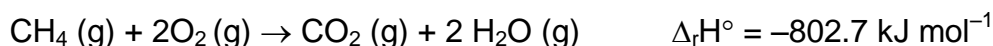

Problem 5 The industrial preparation of hydrogen

Hydrogen gas may be prepared industrially by heating hydrocarbons, such as a methane, with steam:



- a) Given the following thermodynamic data, calculate the $\Delta_r\text{G}^\circ$ for reaction **A** at 298 K and hence a value for the equilibrium constant, K_p .

	$\Delta_f H^\circ (298) / \text{kJ mol}^{-1}$	$S^\circ (298) / \text{J K}^{-1} \text{mol}^{-1}$
CH ₄ (g)	-74.4	186.3
H ₂ O (g)	-241.8	188.8
H ₂ (g)		130.7
CO (g)	-110.5	197.7

b) How will the equilibrium constant vary with temperature?

The industrial preparation can be carried out at atmospheric pressure and high temperature, without a catalyst. Typically, 0.2 vol % of methane gas remains in the mixture at equilibrium.

- c)** Assuming the reaction started with equal volumes of methane and steam, calculate the value of K_p for the industrial process which gives 0.2 vol % methane at equilibrium.
- d)** Use your answer from **(c)** together with the integrated form of the van't Hoff isochore to estimate the temperature used in industry for the preparation of hydrogen from methane.

Problem 6 *The bonds in dibenzyl*

This question is a typical application of thermodynamic cycles to estimate a bond dissociation enthalpy.

The first step in the pyrolysis of toluene (methylbenzene) is the breaking of the C₆H₅CH₂-H bond. The activation enthalpy for this process, which is essentially the bond dissociation enthalpy, is found to be 378.4 kJ mol⁻¹.

a) Write a balanced equation for the complete combustion of toluene.

Standard enthalpies are given below, using the recommended IUPAC notation (i.e. f = formation, c = combustion, vap = vaporisation, at = atomisation)

$$\Delta_f H^\circ(\text{CO}_2, \text{g}, 298\text{K}) = -393.5 \text{ kJ mol}^{-1}$$

$$\Delta_f H^\circ(\text{H}_2\text{O}, \text{l}, 298\text{K}) = -285.8 \text{ kJ mol}^{-1}$$

$$\Delta_c H^\circ(\text{C}_7\text{H}_8, \text{l}, 298\text{K}) = -3910.2 \text{ kJ mol}^{-1}$$

$$\Delta_{\text{vap}} H^\circ(\text{C}_7\text{H}_8, \text{l}, 298\text{K}) = +38.0 \text{ kJ mol}^{-1}$$

$$\Delta_{\text{at}} H^\circ(\text{H}_2, \text{g}, 298\text{K}) = +436.0 \text{ kJ mol}^{-1}.$$

- i) Calculate $\Delta_f H^\circ(\text{C}_7\text{H}_8, \text{l}, 298\text{K})$
- ii) Estimate $\Delta_f H^\circ$ for the benzyl radical $\text{C}_6\text{H}_5\text{CH}_2\cdot(\text{g})$ at 298 K.
- b)** The standard entropy of vaporisation of toluene is $99.0 \text{ J K}^{-1} \text{ mol}^{-1}$.
- i) Calculate $\Delta_{\text{vap}} G^\circ$ for toluene at 298 K.
- ii) What is the reference state of toluene at 298 K?
- iii) Calculate the normal boiling point of toluene.
- c)** The standard enthalpy of formation of dibenzyl (1,2-diphenylethane) is $143.9 \text{ kJ mol}^{-1}$. Calculate the bond dissociation enthalpy for the central C–C bond in dibenzyl, $\text{C}_6\text{H}_5\text{CH}_2\text{–CH}_2\text{C}_6\text{H}_5$.

Problem 7 *Interstellar chemistry*

A possible ion–molecule reaction mechanism for the synthesis of ammonia in interstellar gas clouds is shown below

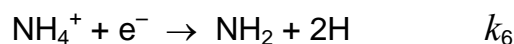
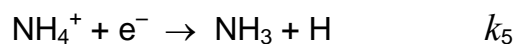
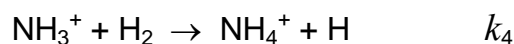
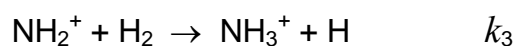
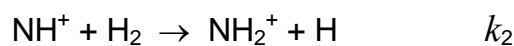
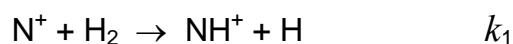

- a)** Use the steady state approximation to derive equations for the concentrations of the intermediates NH^+ , NH_2^+ , NH_3^+ and NH_4^+ in terms of the reactant concentrations $[\text{N}^+]$, $[\text{H}_2]$ and $[\text{e}^-]$. Treat the electrons as you would any other reactant.

b) Show that the overall rate of production of NH_3 is given by

$$\frac{d[\text{NH}_3]}{dt} = k_{2\text{nd}}[\text{N}^+][\text{H}_2]$$

where $k_{2\text{nd}}$ is the second order rate constant for the reaction. Give an expression for $k_{2\text{nd}}$ in terms of the rate constants for the elementary steps, k_1 to k_6 .

c) What is the origin of the activation energy in a chemical reaction?

The rates of many ion-molecule reactions show virtually no dependence on temperature.

d) What does this imply about their activation energy?

e) What relevance does this have to reactions occurring in the interstellar medium?

Problem 8 Simple collision theory

For the elementary gas phase reaction $\text{H} + \text{C}_2\text{H}_4 \rightarrow \text{C}_2\text{H}_5$, the second-order rate constant varies with temperature in the following way:

T / K	198	298	400	511	604
$k \times 10^{12} / \text{cm}^3 \text{ molecule}^{-1} \text{ s}^{-1}$	0.20	1.13	2.83	4.27	7.69

a) Use the data to calculate the activation energy, E_a , and the pre-exponential factor, A , for the reaction.

The simple collision theory of bimolecular reactions yields the following expression for the rate constant:

$$k = \sigma \sqrt{\frac{8k_B T}{\pi \mu}} \exp\left(-\frac{E_a}{RT}\right)$$

where μ is the reduced mass of the reactants and σ is the reaction cross section.

b) Interpret the role of the three factors in this expression; σ , the exponential, and the square-root term.

c) Use the answer to part (a) to estimate σ for the reaction at 400 K.

- d) Compare the value obtained with an estimate of $4.0 \times 10^{-19} \text{ m}^2$ for the collision cross section.

Problem 9 *Hinshelwood*

Sir C.N. Hinshelwood shared the 1956 Nobel prize in Chemistry for his work on the mechanisms of high temperature reactions.

- a) The pyrolysis of ethanal proceeds by the following simplified mechanism:

reaction	rate constant	$E_a / \text{kJ mol}^{-1}$
$\text{CH}_3\text{CHO} \rightarrow \text{CH}_3\cdot + \text{HCO}\cdot$	k_1	358
$\text{CH}_3\cdot + \text{CH}_3\text{CHO} \rightarrow \text{CH}_4 + \text{CH}_3\text{CO}\cdot$	k_2	8
$\text{CH}_3\text{CO}\cdot \rightarrow \text{CH}_3\cdot + \text{CO}$	k_3	59
$\text{HCO}\cdot \rightarrow \text{H}\cdot + \text{CO}$	k_4	65
$\text{H}\cdot + \text{CH}_3\text{CHO} \rightarrow \text{H}_2 + \text{CH}_3\text{CO}\cdot$	k_5	15
$2\text{CH}_3\cdot \rightarrow \text{C}_2\text{H}_6$	k_6	0

- b) List each reaction as initiation, propagation or termination.
- c) Use the steady-state approximation on the radical intermediates to find expressions for the steady-state concentrations of the HCO, H, CH₃ and CH₃CO radicals.
- d) Find rate laws for the rate of loss of ethanal, and the rates of formation of methane, ethane, hydrogen and CO.
- e) There are two pathways for the dissociation of ethanal. Write a balanced equation for each reaction and for each find the order with respect to ethanal, and the activation energy.

Problem 10 Enzyme kinetics

Characterisation of enzyme kinetics can play an important role in drug discovery. A good understanding of how the enzyme behaves in the presence of its natural substrate is necessary before the effect of potential drugs can be evaluated. Enzymes are typically characterised by two parameters, V_{\max} and K_m ; these are determined by analysing the variation of the initial rate of reaction with substrate concentration.

Many enzymatic reactions can be modelled using the scheme:

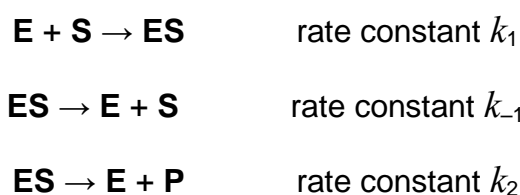

where **E** is the free enzyme, **S** is the substrate, **ES** is a complex formed between the enzyme and substrate and **P** is the product.

- a) Assuming that the system is in steady state and that $[\mathbf{S}] \gg [\mathbf{E}]$ obtain an expression
- for the rate of production of **ES** in terms of $[\mathbf{E}]$, $[\mathbf{S}]$, $[\mathbf{ES}]$ and the appropriate rate constants.
 - for the rate of production of **P** in terms of $[\mathbf{ES}]$ and the appropriate rate constants.

When doing the experiment $[\mathbf{E}]$ is not known, however the total amount of enzyme present is constant throughout the reaction, therefore:

$$[\mathbf{E}]_0 = [\mathbf{E}] + [\mathbf{ES}]$$

where $[\mathbf{E}]_0$ is the initial enzyme concentration.

Also, in enzyme kinetics the Michaelis constant, K_m , is defined as:

$$K_m = (k_{-1} + k_2) / k_1$$

- b) Obtain an expression for $[\mathbf{ES}]$ in terms of $[\mathbf{S}]$, $[\mathbf{E}]_0$ and K_m .
- c) Hence obtain an expression for the rate of production of **P** in terms of $[\mathbf{E}]_0$, $[\mathbf{S}]$ and the appropriate constants.

The maximal rate of reaction, V_{\max} , occurs when all of the enzyme molecules have substrate bound, i.e. when $[ES] = [E]_0$, therefore:

$$V_{\max} = k_2 \times [E]_0$$

- d) Obtain an expression for the rate of production of **P** in terms of V_{\max} , $[S]$ and the appropriate constants.

The enzyme *GTP cyclohydrolase II* catalyses the first step in riboflavin biosynthesis in bacteria:

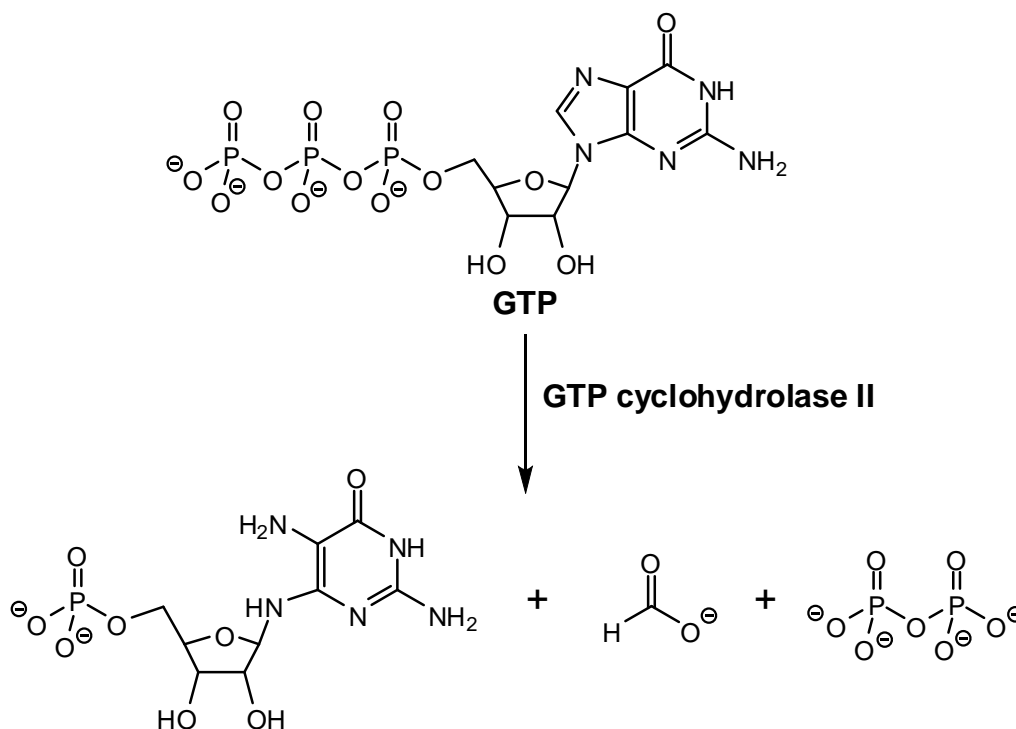

The absence of this enzyme in higher organisms makes GTP cyclohydrolase II a potential target for antimicrobial drugs.

Protein samples were rapidly mixed with different concentrations of GTP. The change in absorbance with time was measured at 299 nm in a 1 ml cell with a 1 cm pathlength. A 100 μM solution of the purified product gave an absorbance of 0.9 in a 1 cm pathlength cell at 299 nm.

Time / s	GTP concentration						
	200 μM	150 μM	100 μM	80 μM	60 μM	40 μM	20 μM
6	0.00514	0.00469	0.00445	0.00393	0.00377	0.00259	0.00197
7	0.00583	0.00547	0.00477	0.00454	0.00388	0.00253	0.00247
8	0.00708	0.00639	0.00568	0.00506	0.00452	0.00309	0.00253
9	0.00698	0.00703	0.00639	0.00591	0.00521	0.00325	0.00295
10	0.00818	0.00800	0.00709	0.00645	0.00574	0.00387	0.00302
11	0.00901	0.00884	0.00752	0.00702	0.00638	0.00445	0.00352
12	0.0103	0.00922	0.00849	0.00771	0.00707	0.00495	0.00386

- e) Calculate the initial rate of reaction at each of the GTP concentrations.
- f) Express the equation obtained in part (d) in the form $y = mx + c$.
- g) Hence determine V_{max} and K_m for this enzyme (you may assume that the kinetic scheme outlined above is valid for this enzyme)

Problem 11 Hydrocyanic acid

Hydrocyanic acid is a weak acid with dissociation constant $K_a = 4.93 \times 10^{-10}$

- a) Find the pH of a 1.00 M solution of HCN.
- b) 10 L of pure water is accidentally contaminated by NaCN. The pH is found to be 7.40. Deduce the concentrations of each of the species, Na^+ , H^+ , OH^- , CN^- , HCN, and hence calculate the mass of NaCN added.

Problem 12 Chlorine electrochemistry

- a) State the Nernst equation.
- b) You are given the following set of standard electrode potentials and half cell reactions for chlorine.

Alkaline	E° / V	Acidic	E° / V
$\text{ClO}_4^- + \text{H}_2\text{O} / \text{ClO}_3^- + 2\text{OH}^-$	0.37	$\text{ClO}_4^- + 2\text{H}^+ / \text{ClO}_3^- + \text{H}_2\text{O}$	1.20
$\text{ClO}_3^- + \text{H}_2\text{O} / \text{ClO}_2^- + 2\text{OH}^-$	0.30	$\text{ClO}_3^- + 3\text{H}^+ / \text{HClO}_2 + \text{H}_2\text{O}$	1.19
$\text{ClO}_2^- + \text{H}_2\text{O} / \text{ClO}^- + 2\text{OH}^-$	0.68	$\text{HClO}_2 + 2\text{H}^+ / \text{HOCl} + \text{H}_2\text{O}$	1.67
$\text{ClO}^- + \text{H}_2\text{O} / \frac{1}{2}\text{Cl}_2 + 2\text{OH}^-$	0.42	$\text{HOCl} + \text{H}^+ / \frac{1}{2}\text{Cl}_2 + \text{H}_2\text{O}$	1.63
$\frac{1}{2}\text{Cl}_2 / \text{Cl}^-$	1.36	$\frac{1}{2}\text{Cl}_2 / \text{Cl}^-$	1.36

Calculate the following quantities

- The ionic product of water, K_w .
- The equilibrium constants for the disproportionation reaction of chlorine to oxidation states +1 and -1 under both acidic and alkaline conditions.
- The $\text{p}K_a$ value for HOCl.
- The concentrations at pH 7.5 of HOCl and ClO^- in a solution where the total concentration of hypochlorite (chlorate (I)) is $0.20 \text{ mmol dm}^{-3}$, and the electrode potential for the reduction of this system to chlorine at this pH with unit activity of chlorine. These conditions are typical of a swimming pool.

Problem 13 The solubility of CuBr

The EMF of the cell

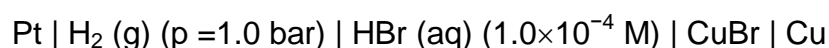

is 0.559 V at 298 K. (Assume that all species in the cell behave ideally).

- Write down half cell reactions for the right and left hand electrodes, the Nernst equation for the cell and the standard electrode potential for the CuBr electrode.
- The standard electrode potential for the Cu/Cu⁺ (aq) couple is 0.522 V. Calculate ΔG° for the dissolution of CuBr at 298 K and hence the solubility product of CuBr.
- Calculate the concentration of Cu⁺ (aq) ions in the cell shown above.
- By how much would the EMF of the cell change if the pressure of hydrogen were doubled?

Problem 14 Electrochemical equilibria

- Calculate the standard electrode potential for the aqueous couple [Fe(CN)₆]³⁻ / [Fe(CN)₆]⁴⁻ from the following data:

$$E^\circ(\text{Fe}^{3+}(\text{aq}) \mid \text{Fe}^{2+}(\text{aq})) = + 0.770 \text{ V}$$

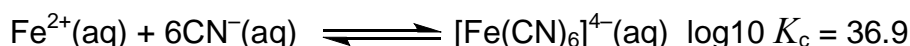
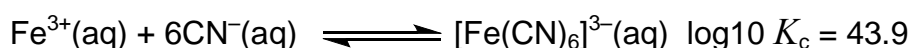

The following standard electrode potentials have been reported:



- Calculate the equilibrium constant for the disproportionation reaction $3\text{M}^{+}(\text{aq}) \rightarrow \text{M}^{3+}(\text{aq}) + 2\text{M}(\text{s})$ for In and Tl. Comment on the result.

Problem 15 Photodissociation of Cl_2

Photodissociation is the process in which a molecule fragments after absorbing a photon with sufficient energy to break a chemical bond. The rupture of a chemical bond is one of the most fundamental chemical processes, and has been studied in great detail.

In a modified time-of-flight mass spectroscopy technique for studying Cl–Cl bond cleavage, a laser beam is crossed with a molecular beam of Cl_2 , and dissociation occurs at the crossing point. A second laser beam ionises the resulting Cl atoms (without affecting their velocities), so that a carefully tuned electric field may be used to guide them along a 40 cm flight path to a position sensitive detector.

The image of the Cl fragments recorded at the detector is shown on the right. Note that this represents a two-dimensional projection of the full three-dimensional velocity distribution.

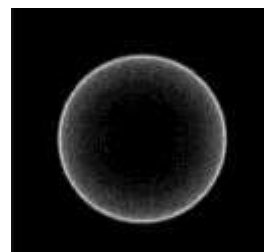

- A potential of 3000 V is used to direct the ionised Cl atoms to the detector. What is their flight time? Take the mass of a Cl atom to be 35 g mol^{-1} .
- The image appears as a single ring of Cl atoms as a result of conservation of energy and momentum. The outside diameter of the ring is 12.68 mm. What velocity did the Cl atoms acquire as a result of the photodissociation?
- The bond dissociation energy of Cl_2 is 243 kJ mol^{-1} . Use conservation of energy to determine the laser wavelength.

Problem 16 Laser Cooling

This question is about laser cooling, which is a quick and efficient way of cooling ions down to very cold temperatures. The mean kinetic energy of a molecule is related to its temperature by $E = \frac{3}{2} k_{\text{B}} T$, where k_{B} is the Boltzmann constant.

- Calcium atoms leak out of an oven at $600 \text{ }^\circ\text{C}$. Calculate the mean kinetic energy of the calcium atoms and hence the rms momentum and rms speed of a ^{40}Ca atom, whose relative isotopic mass is 39.96.

- b)** The atoms drift into an ion trap where they are photoionised and trapped. While in this trap they are bombarded with laser light of wavelength 396.96 nm. Calculate the frequency, energy and momentum of a photon with this wavelength.
- c)** The ions go through an optical cycle repeatedly. Ions absorb a photon from the laser when they are moving in the opposite direction to the light (this is achieved using the Doppler Effect) and then re-emit a photon in a random direction. The net effect of this procedure is to slow the ion down slightly. Calculate the change in mean momentum and speed at each cycle and the number of photons that would need to be absorbed to bring the ion approximately to rest. (In practice this process was found to reduce the temperature to about 0.5 mK.)
- d)** Write down the ground electronic configuration of the Ca^+ ion, and calculate the orbital and spin angular momentum of the unpaired electron.
- e)** In the excited configuration involved in the laser cooling transition the unpaired electron has been excited into the lowest available p orbital. Calculate the orbital and spin angular momentum of the unpaired electron.
- f)** In this excited state the electron experiences a magnetic field because of its own orbital motion around the charged nucleus. The spin of the electron can line up either parallel or antiparallel to this field, and the two states have slightly different energies. The resultant quantum number, j , for the total electronic angular momentum takes values from $|l - s|$ to $|l + s|$ in integer steps. Calculate the possible values of j .
- g)** The laser cooling transition is to the lower of these two levels, the transition from the ground state to the higher level has a wavelength 393.48 nm. Calculate the energy difference between the two levels resulting from the excited configuration.

Problem 17 Hydrogen bond strength determination

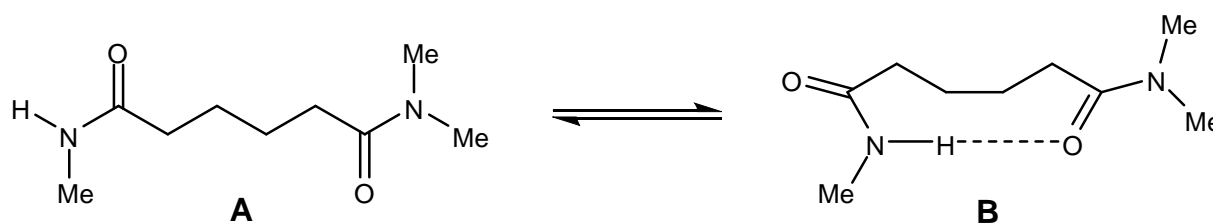

In an experiment to measure the strength of the intramolecular hydrogen-bond in **B**, the chemical shift of the amide proton δ_{obs} , was measured at various temperatures.

T / K	δ_{obs} / ppm
220	6.67
240	6.50
260	6.37
280	6.27
300	6.19

The observed chemical shift, δ_{obs} , is the weighted average of the shifts of the N–H proton when the amide is completely hydrogen bonded, δ_{h} , and when it is completely free, δ_{f} .

- Derive an expression for the observed chemical shift of the N–H proton, δ_{obs} .
- Derive an expression for the equilibrium constant K for **A** \rightleftharpoons **B** in terms of δ_{obs} , δ_{h} , and δ_{f} .
- Given that $\delta_{\text{h}} = 8.4$ ppm and $\delta_{\text{f}} = 5.7$ ppm, calculate the equilibrium constants for the cyclisation at the different temperatures.
- By plotting a suitable graph, determine the standard enthalpy change for **A** \rightarrow **B** and the standard change in entropy at 300 K.
- Discuss the significance of your answers to part (b).

Problem 18 Magnetic Complexes

Reaction of FeCl_2 with phenanthroline (phen) and two equivalents of $\text{K}[\text{NCS}]$ yields the octahedral iron (II) complex $\text{Fe}(\text{phen})_2(\text{NCS})_2$ (**A**). At liquid nitrogen temperature **A** has a magnetic moment of 0.0 B.M. but a magnetic moment near 4.9 B.M. at room temperature. [The effective magnetic moment, μ_{eff} , for a complex containing n unpaired electrons is given by: $\mu_{\text{eff}} = \sqrt{n(n+2)}$ Bohr magnetons, B.M.]

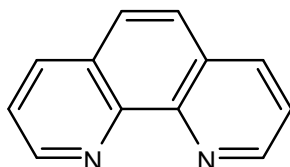

Phenanthroline

- Draw structures of the possible isomers of **A**
- Determine the number of valence electrons which occupy the d -orbitals of **A**
- Draw electronic configurations for the d -orbital occupancy consistent with the high temperature and low temperature magnetic behaviour of **A** [You should determine the expected effective magnetic moment in each case]
- Which of the following statements is/are consistent with the low temperature magnetic data:

	YES	NO	INSUFFICIENT DATA
Hund's Rules are obeyed	<input type="checkbox"/>	<input type="checkbox"/>	<input type="checkbox"/>
The Pauli Exclusion Principle is obeyed	<input type="checkbox"/>	<input type="checkbox"/>	<input type="checkbox"/>

- Which of the following statements is/are consistent with the high temperature magnetic data:

	YES	NO	INSUFFICIENT DATA
Hund's Rules are obeyed	<input type="checkbox"/>	<input type="checkbox"/>	<input type="checkbox"/>
The Pauli Exclusion Principle is obeyed	<input type="checkbox"/>	<input type="checkbox"/>	<input type="checkbox"/>

The ligand Hacac (**B**, $\text{C}_5\text{H}_8\text{O}_2$) is shown below. Treatment with NH_3 yields the anion acac^- (**C**) whose C–O bond lengths are longer than those in **B** and whose ^1H NMR exhibits just two peaks. Addition of three equivalents of acac^- to an aqueous solution

of FeCl_3 yields a bright red octahedral complex (**D**) of composition $\text{C}_{15}\text{H}_{21}\text{O}_6\text{Fe}$ with an effective magnetic moment of 5.9 B.M.

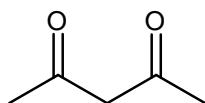

Hacac

- Draw the anion acac^- (**C**) and determine a resonance structure to explain the difference in C–O bond lengths between **B** and **C**.
- Draw the structures of **B** and **C** and clearly label the hybridisation state at each carbon in each case.
- Draw possible isomers of **D** and predict the d -orbital occupancy in light of the observed magnetic data.

Problem 19 Explosive S_4N_4

Bubbling gaseous NH_3 through a solution of SCl_2 generates a red explosive solid, S_4N_4 . Its structure can be represented in a number of ways; one way is as shown below.

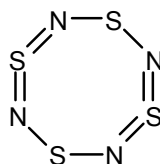

- Write a balanced equation for the formation of S_4N_4 from NH_3 and SCl_2
- Construct a Born-Haber cycle for the formation of S_4N_4 and use the data below to determine the enthalpy of formation of S_4N_4
- Use the additional data and your answer to part (a) to determine the enthalpy change for the reaction of NH_3 with SCl_2

The S_4N_4 molecule has a rich reaction chemistry including both oxidation and reduction reactions. Treatment of S_4N_4 with an excess of AsF_5 in sulfur dioxide generates the salt $[\text{S}_4\text{N}_4][\text{AsF}_6]_2$ whereas treatment with excess $\text{SnCl}_2 \cdot 2\text{H}_2\text{O}$ in methanol yields $\text{S}_4\text{N}_4\text{H}_4$

- Write balanced equations for these two reactions

$$E(\text{S-S}) = 226 \text{ kJ mol}^{-1}$$

$$E(\text{N}\equiv\text{N}) = 946 \text{ kJ mol}^{-1}$$

$$E(\text{S-N}) = 273 \text{ kJ mol}^{-1}$$

$$E(\text{S=N}) = 328 \text{ kJ mol}^{-1}$$

$$\Delta H_{\text{vap}}(\text{S}_8) = 77 \text{ kJ mol}^{-1}$$

$$\Delta H_{\text{vap}}(\text{S}_4\text{N}_4) = 88 \text{ kJ mol}^{-1}$$

$$\Delta_f H (\text{NH}_3) = -45.9 \text{ kJ mol}^{-1}$$

$$\Delta_f H (\text{SCl}_2) = -50.0 \text{ kJ mol}^{-1}$$

$$\Delta_f H (\text{HCl}) = -92.3 \text{ kJ mol}^{-1}$$

Problem 20 Sulfur compounds

Identify the compounds **A** to **D** in the scheme shown below and describe their structures with the aid of suitable sketches.

You may wish to refer to the following additional information :

Compound **A** is a yellow liquid containing 52.5% Cl and 47.5% S.

Compound **B** is a moisture-sensitive, red liquid.

Compound **C** is a colourless liquid containing 59.6% Cl, 26.95% S and 13.45% O.

Compound **D** has a relative molar mass of $134.96 \text{ g mol}^{-1}$. Compound **D** can also be obtained by direct reaction of **C** with O_2 .

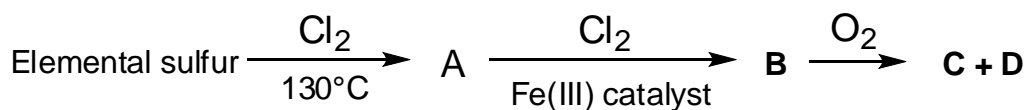

Problem 21 Reactions of sodium

The scheme below summarises some reactions of sodium metal.

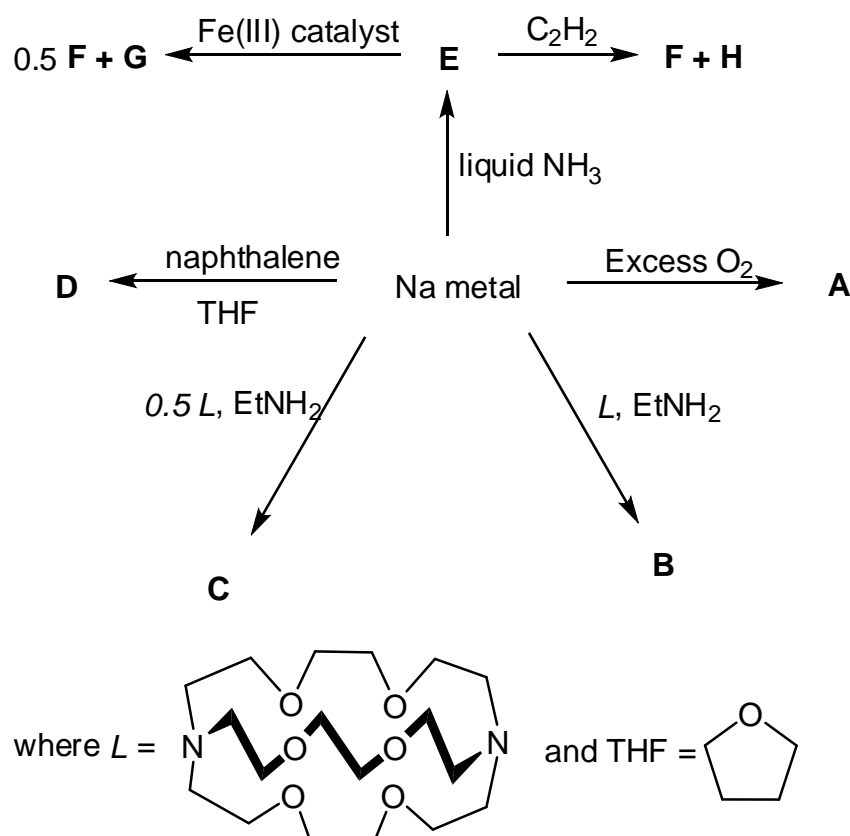

- Compound **A** is white, crystalline solids. Identify it and discuss the bonding in the anion. How do the metals Li and K react with excess O_2 ?
- Compounds **B** and **C** are both deeply coloured solids. Identify each of them and briefly discuss the driving force for their formation. Note that the EtNH_2 acts only as a solvent for these reactions.
- Solutions of **D** and **E** are deep green and blue, respectively. What are the species present in these solutions?
- Compound **G** is a white crystalline ionic solid, while **F** is a colourless, highly flammable gas that does not condense in liquid NH_3 . Identify **F** and **G**.
- Compound **H** is a white, ionic solid. One mole of the gas **F** is formed for each mole of **H** that is formed. Identify compound **H**.

Problem 22 Chlorine compounds

Compounds **A** to **I** all contain chlorine.

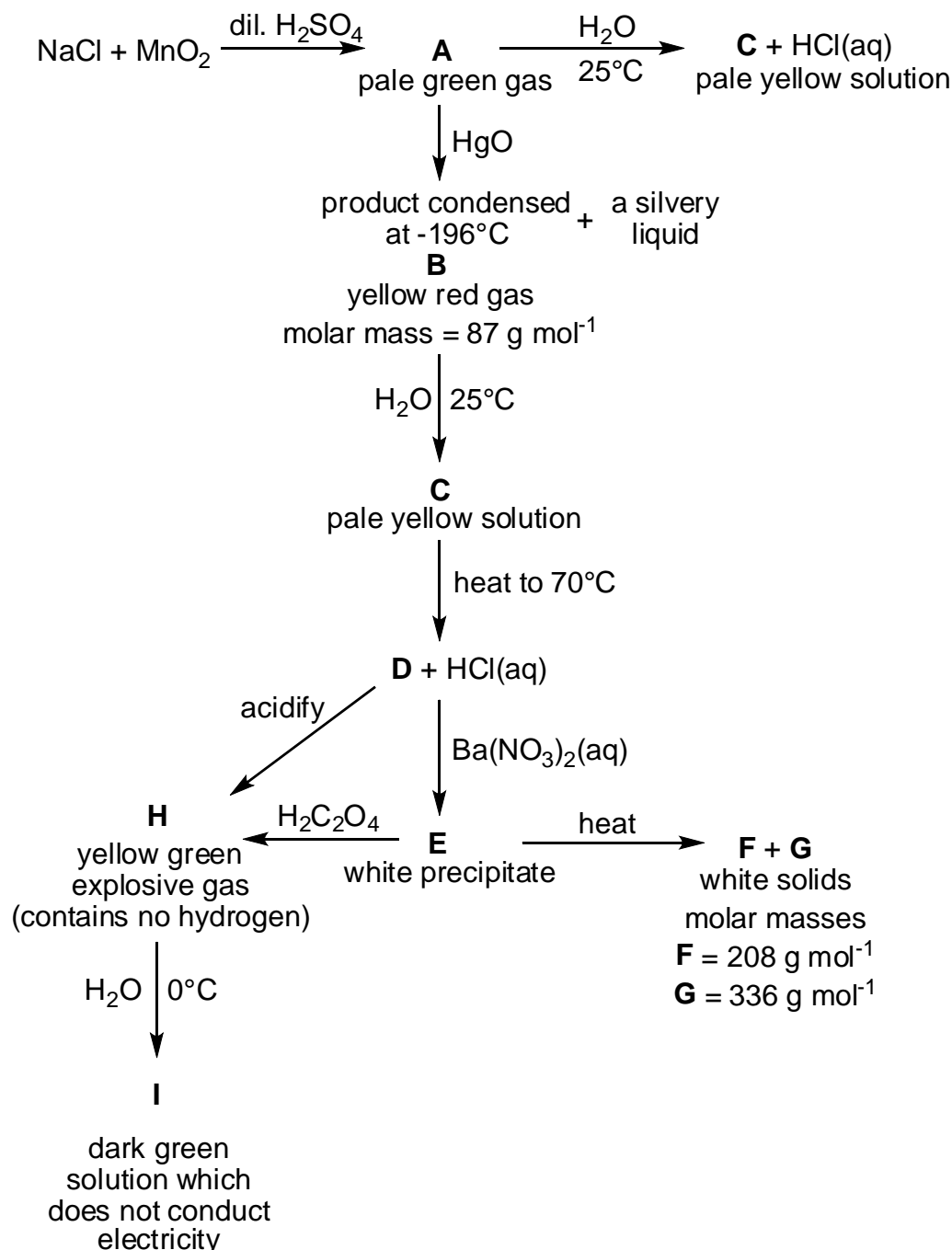

a) Identify **A** to **I** and write balanced equations for the following reactions:

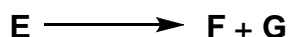
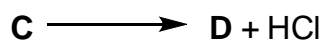
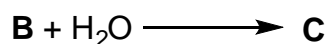
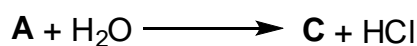

- b) Predict the structures of **B**, **D**, **F** and **H**, and comment on points of interest in the structure of **H**
- c) Comment on the conditions used in the sequence of reactions:

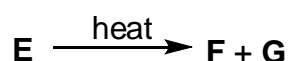
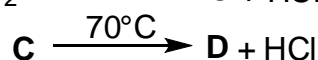
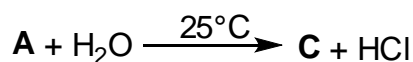

Problem 23 Perkin Junior

Sir William Henry Perkin accidentally discovered “mauveine”, the first commercial synthetic dyestuff, in 1856 while working in his home laboratory. His love of chemistry was passed on to his eldest son William Henry Perkin, Jr. (1860-1929). William Henry Perkin Jr is best known for his work on the synthesis and structure elucidation of natural products including α -terpineol. Perkin’s synthesis of this monoterpene forms the basis of this question.

As Perkin stated, the synthesis of α -terpineol (**F**) “*was undertaken with the object of synthesising...terpineol..., not only on account of the interest which always attaches to syntheses of this kind, but also in the hope that a method of synthesis might be devised of such a simple kind that there would no longer be room for doubt as to the constitution of these important substances*”.

We begin Perkin's synthesis of α -terpineol with the ketone **A**.

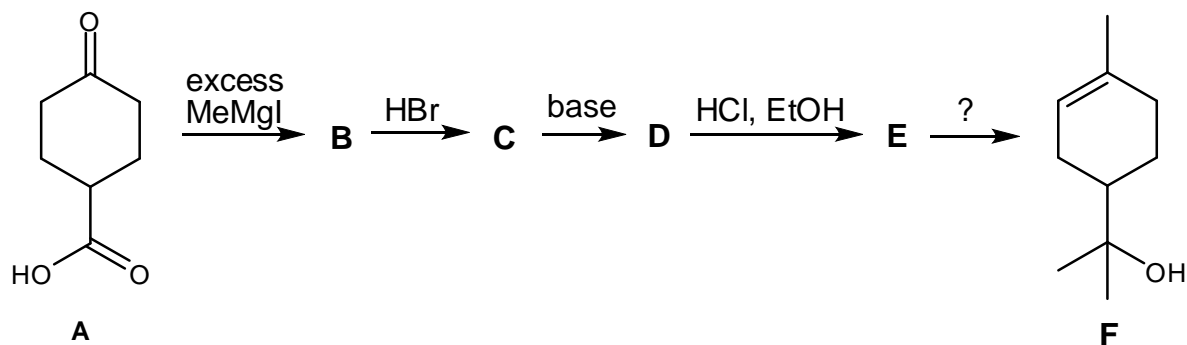

- a) Identify the intermediates **B**, **C**, **D** and **E**.
- b) What reagent would you use to convert **E** into α -terpineol **F**.
- c) Suggest reagents for the preparation of **A** from 4-hydroxybenzoic acid.

α -Terpineol **F** has been used to prepare other monoterpenes.

- d) Treatment of α -terpineol **F** with potassium hydrogen sulfate gave compound **G** which reacts with two equivalents of bromine. Identify **G** given that it is chiral.
- e) Treatment of α -terpineol **F** with aqueous acid gives compound **H**. Exposure of **H** to stronger acid gives **I**. Identify **H** and **I**.

In the ^1H NMR spectrum of **H** addition of D_2O results in the disappearance of one signal corresponding to two hydrogens, whereas the ^1H NMR spectrum of compound **I** remains unchanged on addition of D_2O .

Neither compound **H** nor **I** are chiral, and neither react with bromine.

Problem 24 Cyclooctatetraene

Cyclooctatetraene **H** was an exceedingly important molecule in the development of the theory of organic chemistry. It belongs to a class of compounds which, although they have alternating single and double bonds in a ring, do not benefit from the increase in stability that aromatic compounds such as benzene do. Cyclooctatetraene was first synthesised by Willstätter starting from the natural product pseudopelletierine **A**, according to the scheme below; in 1940 Reppe reported a one step synthesis of cyclooctatetraene from acetylene thus making this previously precious laboratory chemical into a commercially available material.

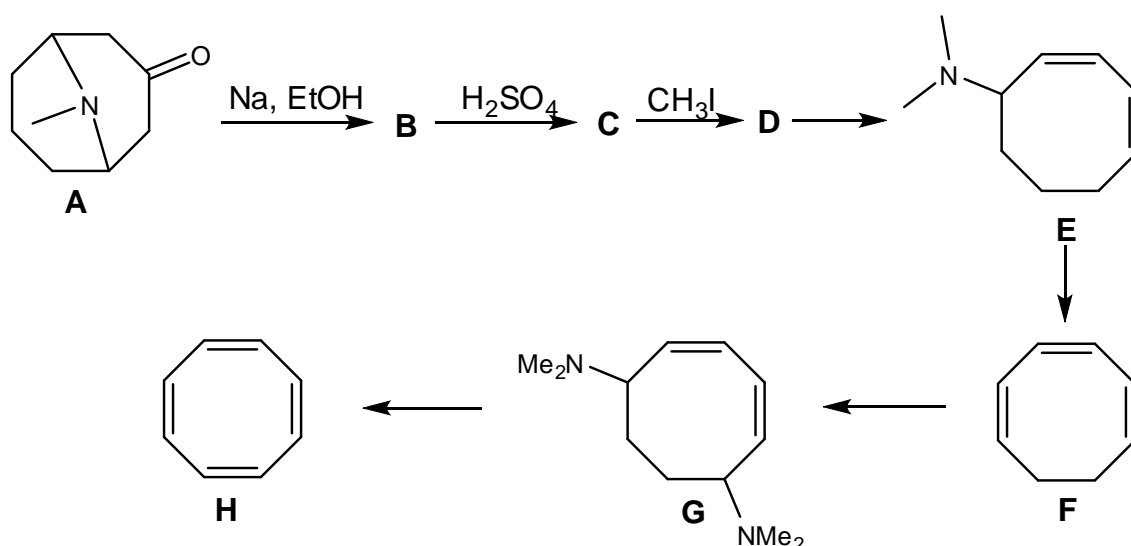

- Identify intermediates **B**, **C**, and **D**
- Suggest reagents for the conversion of **D** into **E**, **E** into **F**, **F** into **G** and **G** into cyclooctatetraene.

Pseudopelletierine **A** is a natural product found in the bark of the pomegranate. Biochemical labelling studies have shown that it is biosynthesised from lysine **W**, and ethanoate via Δ^1 -piperidine **X**, pelletierine **Y** and *N*-methylpelletierine **Z**.

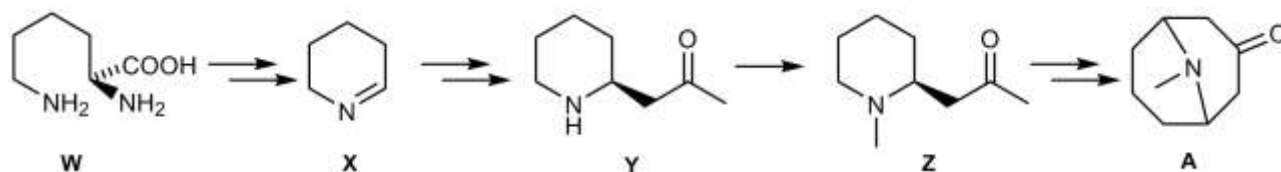

The route by which pelletierine is formed from Δ^1 -piperidine and ethanoate was determined using ^{13}C labelling studies. Four possible routes can be postulated:

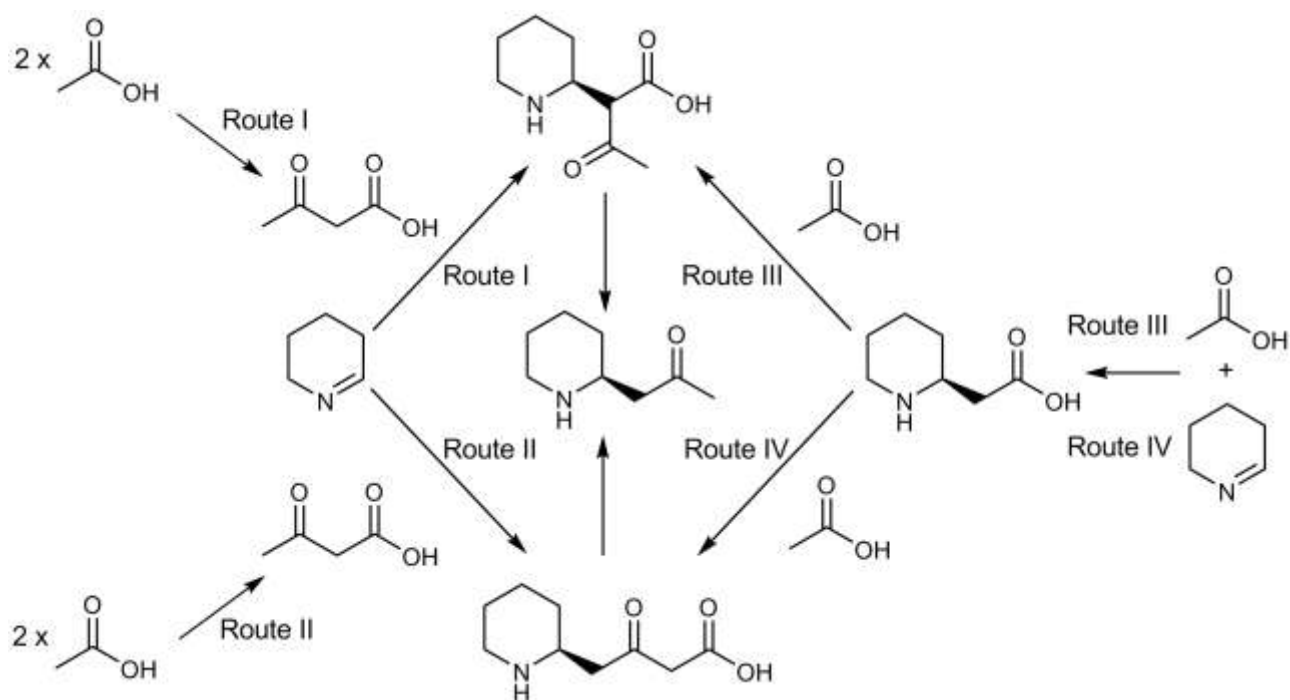

To distinguish between the different biosynthetic routes two experiments were carried out. In the first experiment plants were fed a mixture of sodium ethanoate labelled with ^{13}C at both carbon positions (sodium $[1,2-^{13}\text{C}_2]$ ethanoate) and the unlabelled compound (a mixture was used to increase the probability that only a single labelled ethanoate molecule would be incorporated into each molecule of pelletierene).

- c)** Draw structures of pelletierine indicating the position at which ^{13}C labels would appear in each of the biosynthetic routes. You may assume that in each case only one of the incorporated ethanoate molecules was ^{13}C labelled.
- d)** Which biosynthetic routes can be distinguished in this experiment?

In a second experiment plants were fed a mixture of sodium 3-oxobutanoate labelled with ^{13}C at all carbon positions (sodium $[1,2,3,4-^{13}\text{C}_4]$ 3-oxobutanoate) and the unlabelled compound.

- e)** Which biosynthetic routes can be distinguished in this experiment?

N-methylpelletierene was isolated from plants grown in each of the experiments and also from plants grown in presence of compounds with a natural abundance of ^{13}C (the control experiment). The ^{13}C NMR spectrum of each of the samples was recorded.

In *N*-methylpelletierene isolated from the control experiment atoms labelled **j**, **k** and **l** in the structure shown have ^{13}C NMR chemical shifts of 31.0, 207.8 and 47.1 respectively. Each of these peaks is a singlet.

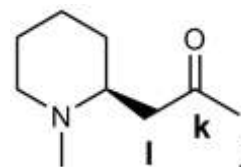

These peaks also appear in the spectra of *N*-methylpelletierene isolated in experiments 1 and 2, however there are also the following additional peaks:

Experiment 1			Experiment 2		
^{13}C shift (ppm)	Multiplicity	Coupling constant (Hz)	^{13}C shift (ppm)	Multiplicity	Coupling constant (Hz)
31.0	doublet	40.4 ± 1.8	31.0	doublet of doublets	39.8 ± 1.8 14.4 ± 1.8
207.8	doublet	39.5 ± 1.8	47.1	doublet of doublets	39.4 ± 1.8 13.7 ± 1.8
			208.7	doublet of doublets	39.4 ± 1.8 39.5 ± 1.8

f) Which route does the biosynthesis of pelletierene follow?

Problem 25 The synthesis of methadone

Methadone

Methadone is an analgesic drug with a similar activity to morphine and is used in treating heroin addicts. It may be prepared as its hydrochloride salt by the following multi-stage synthesis:

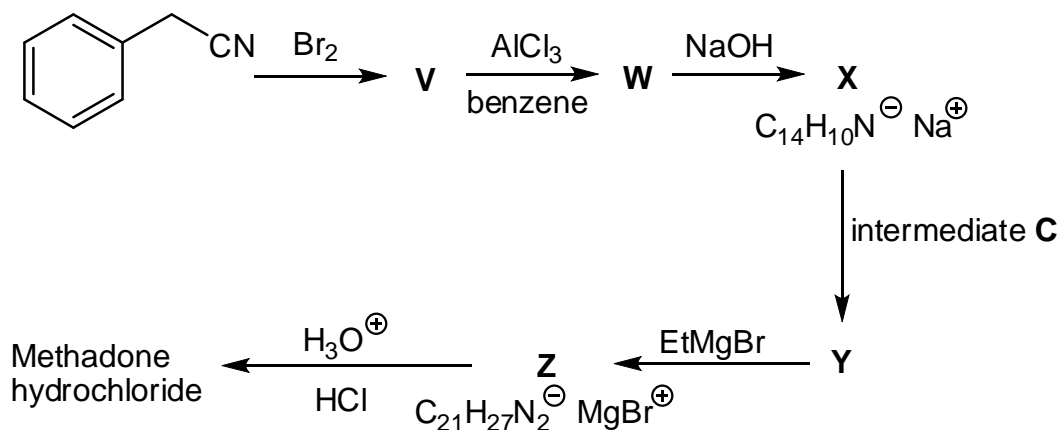

Intermediate **C** is a chloride salt and may be prepared by treating two isomeric compounds with SOCl_2 and then heating up the reaction mixture:

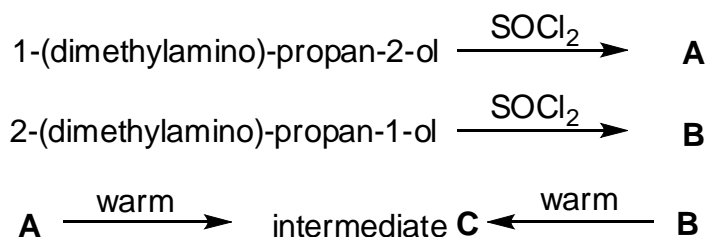

- Deduce the structures for the compounds **V**, **W** and **X**.
- Deduce the structures for the compounds **A**, **B** and hence for the intermediate **C**.
- Deduce the structures for the compounds **Y**, **Z** and methadone hydrochloride.
- Assign, as fully as possible, the ^1H NMR spectrum of methadone.

^1H NMR δ 7.40–7.30 (10H, m), 2.78 (1H, dqd, 10.6 Hz, 6.2 Hz, 2.3 Hz), 2.49 (2H, q, 6.8 Hz), 2.26 (6H, s), 2.22 (1H, dd, 11.5 Hz, 10.6 Hz), 2.00 (1H, dd, 11.5 Hz, 2.3 Hz), 1.10 (3H, d, 6.2 Hz), 1.05 (3H, t, 6.8 Hz).

The synthesis above yields a racemic mixture. In order to obtain the pure, biologically active (*R*)-enantiomer resolution may be achieved by crystallisation with (+)-tartaric acid.

- Draw the structure of the biologically active enantiomer of methadone.

Problem 26 Verapamil

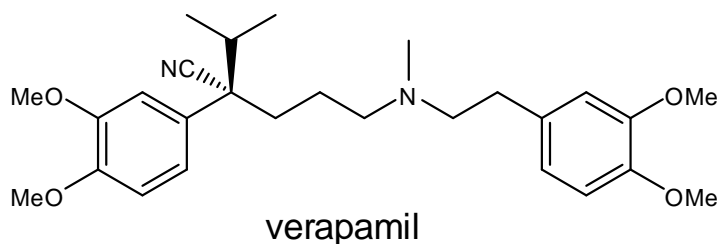

Verapamil is a calcium channel blocker used for, among other things, the treatment of hypertension and cardiac arrhythmia. It can be prepared from the reaction between **H** and **M** which can be synthesised according to the schemes below.

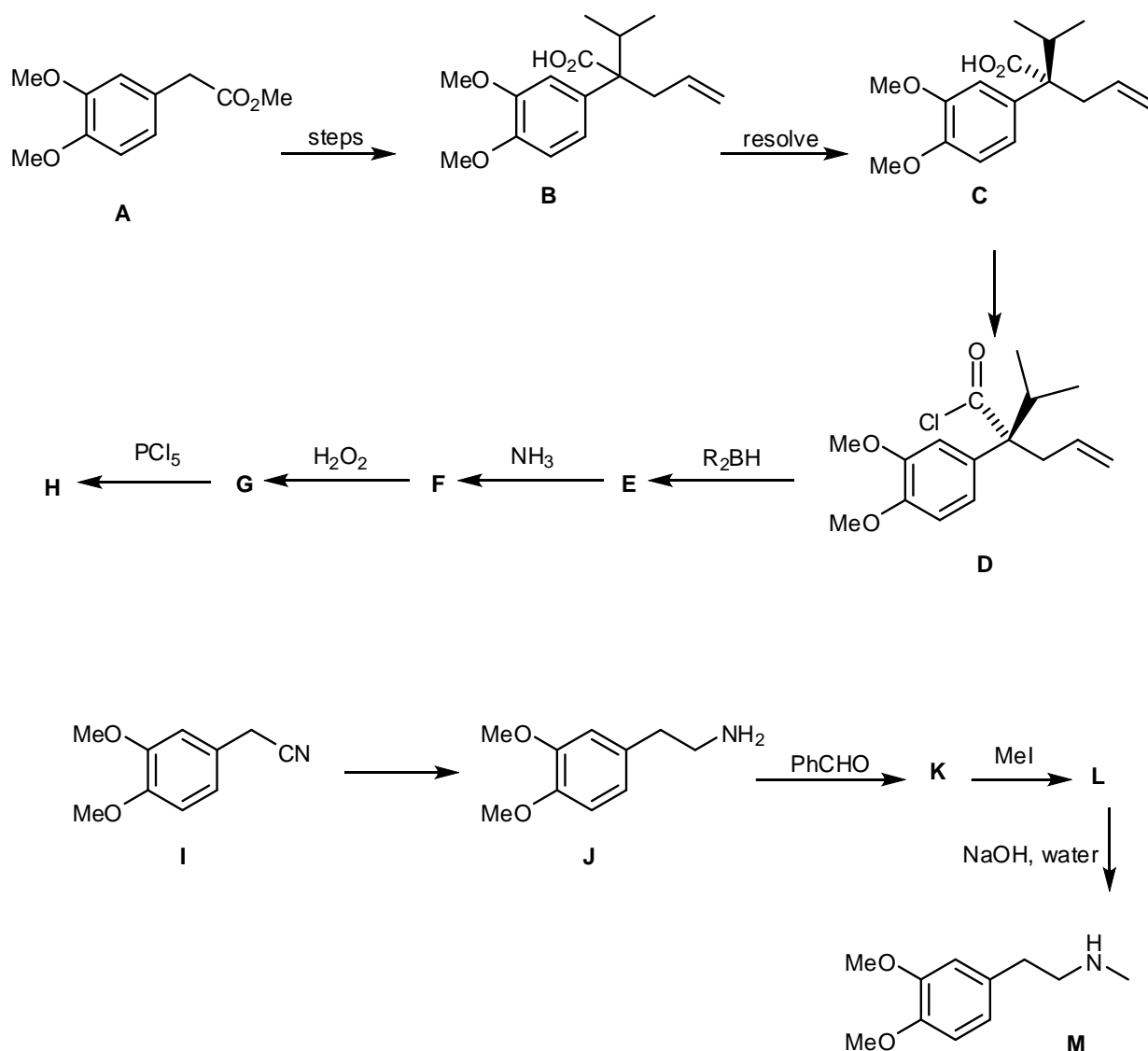

- a) Suggest reagents for the multi-step conversion of **A** into the racemic acid **B**.

The acid **B** can be resolved to give the enantiopure acid **C** on treatment with cinchonidine.

- b) Suggest a reagent for the conversion of **C** in **D**.
- c) Suggest structures for intermediates **E**, **F**, **G** and **H**.
- d) Suggest a reagent for the conversion of **I** into **J**.
- e) Direct monomethylation of amines with MeI is generally not possible and hence amine **J** was converted into amine **M** by way of intermediates **K** and **L**. Suggest structures for **K** and **L**.
- f) How would you prepare the ester **A** from the nitrile **I**.

Problem 27 *Mass spectrometry of a peptide*

Note: the structures, names, and codes of the amino acids are given in the Appendix.

Snake venom is composed of a variety of polypeptides and other small molecules. Venom polypeptides have a range of biological effects including muscle necrosis and the disruption of neurotransmission. Characterisation of the components of snake venom is important in the development of lead-compounds for the pharmaceutical industry and also in the creation of antivenins.

Tandem mass spectrometry (MS-MS) provides a rapid approach for determining the sequence of polypeptides. This involves formation of a parent ion, which is then fragmented to form other smaller ions. In peptides fragmentation often occurs at the amide bond, giving rise to so-called 'b ions'. The b ions formed from an alanine-valine-glycine polypeptide are shown below. Remember that by convention the first amino acid is that with the free -NH_2 group.

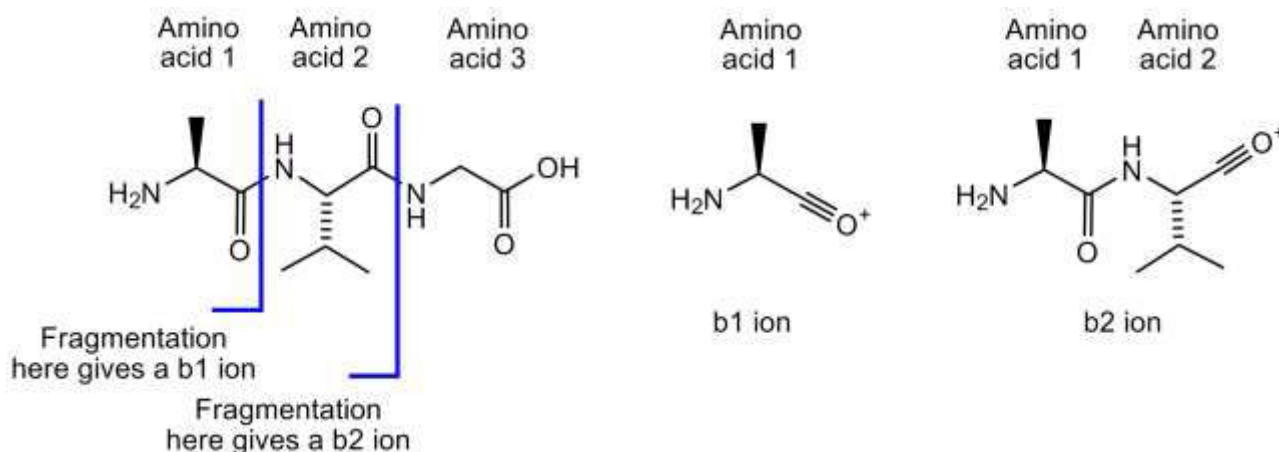

Polypeptide **X** was isolated from the venom of the pit viper, *B. insularis*. The amino acid composition of polypeptide **X** may be found by acid hydrolysis of the peptide. Under the conditions used for the hydrolysis, Asp and Asn are indistinguishable and are termed Asx; similarly Glu and Gln are indistinguishable and termed Glx. The composition of polypeptide **X** was found to be: 1 × Asx, 2 × Glx, 1 × His, 1 × Ile, 4 × Pro and 1 × Trp.

- a) How many unique decapeptide sequences can be formed from these amino acids:
- assuming Glx are both the same amino acid?
 - assuming that one of the Glx amino acids is Glu, the other Gln?
- b) What are the possible masses for Polypeptide **X**?

In the mass spectrum of Polypeptide **X** the parent ion showed at peak at an m/z of 1196.8. It is known that although snake toxins are synthesised from the 20 common amino acids shown in the table some of these amino acids can be chemically modified after polypeptide synthesis. The mass spectrum of the parent ion suggests that one of the amino acids in Polypeptide **X** has been modified in a way that is not evident after acid hydrolysis.

Polypeptide **X** was sequenced using MS-MS. The masses of the b ions are shown in the table below:

ion	m/z	ion	m/z	ion	m/z
b ₁	112.2	b ₄	509.7	b ₇	872.0
b ₂	226.4	b ₅	646.7	b ₈	985.0
b ₃	412.5	b ₆	743.8	b ₉	1082.2

- c) What is the sequence of Polypeptide **X**? You may use Mod for the modified amino acid.
- d) What is the mass of the modified amino acid?

The ¹³C NMR spectra of Mod in D₂O is shown on the right.

The ¹H NMR spectra, taken in an organic solvent, and in D₂O are shown below.

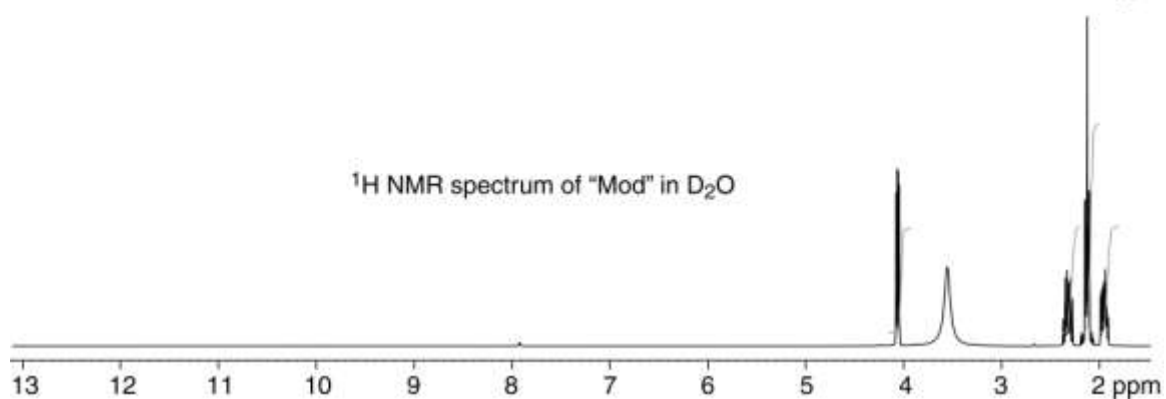
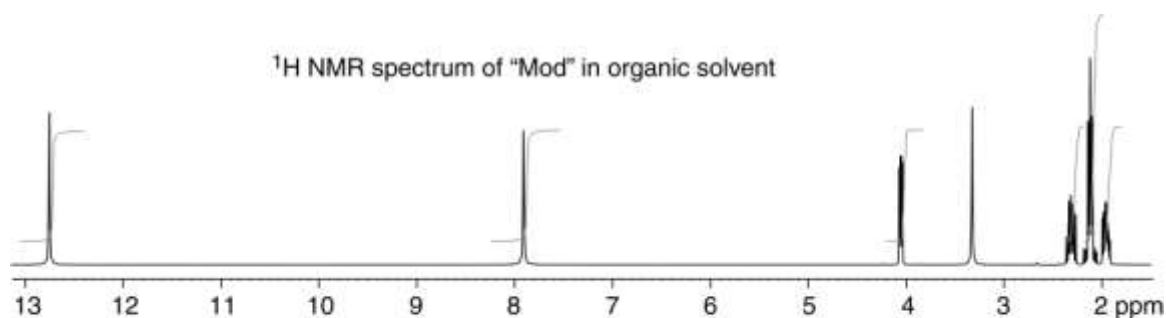
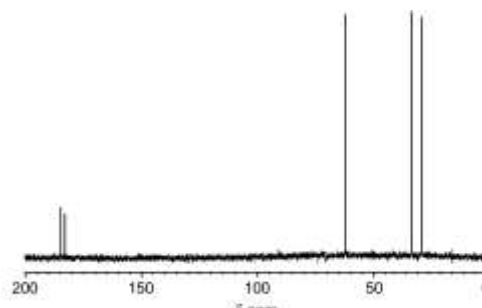

- e) Draw the structure of Mod and suggest which protons give rise to which signals in the ^1H NMR spectrum. You need not explain the multiplicity of the signals.

Problem 28 A fossilized peptide

Note: the structures, names, and codes of the amino acids are given in the Appendix.

Tandem mass spectrometry (MS-MS) provides a rapid approach for determining the sequence of polypeptides. This involves formation of a parent ion, which is then fragmented to form other smaller ions. In peptides fragmentation often occurs along the polypeptide backbone; the fragment ions are named depending on where fragmentation occurs and which atom retains the positive charge. Some of the ions formed in the fragmentation of an alanine-leucine-glycine peptide are shown below:

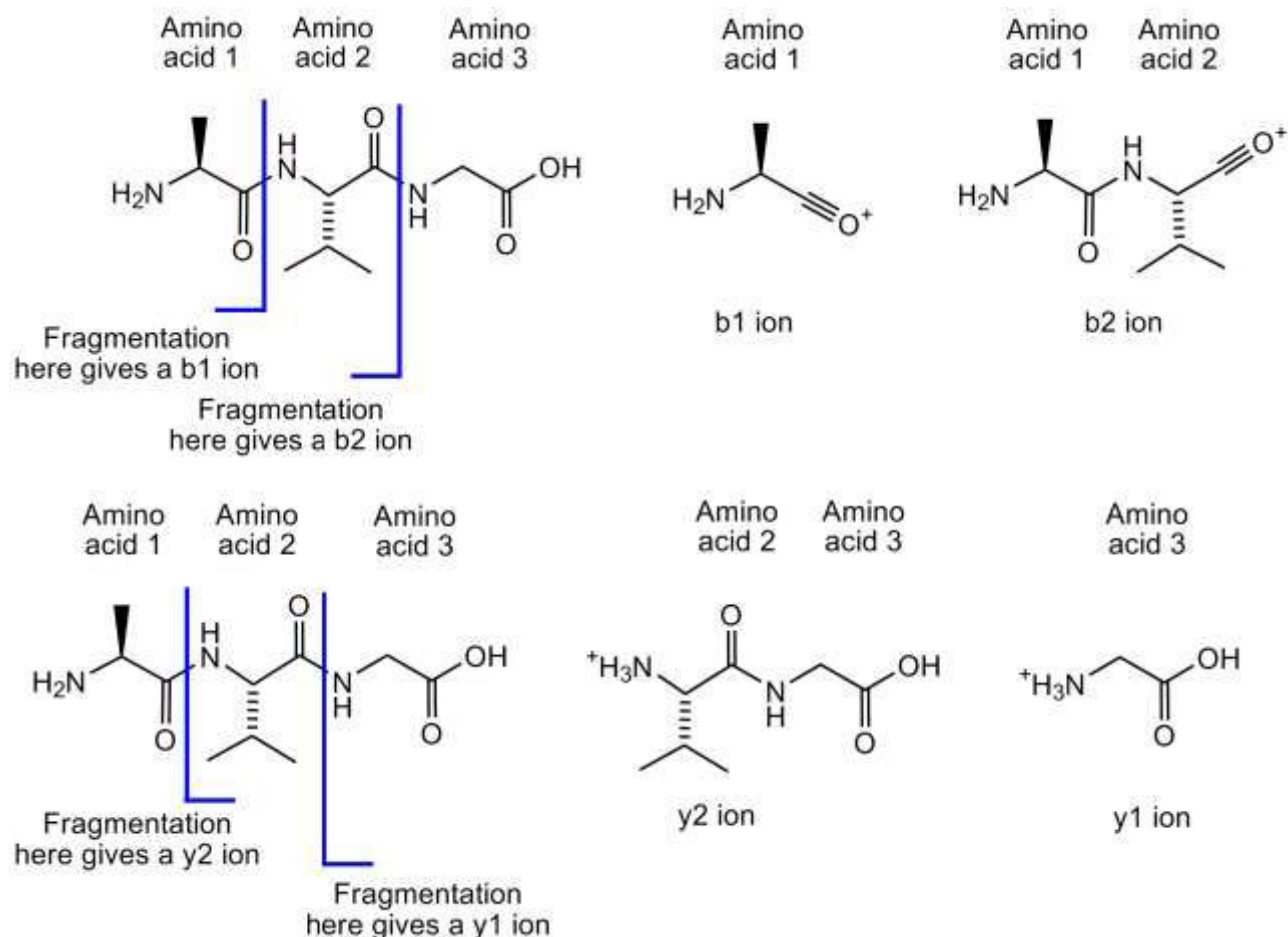

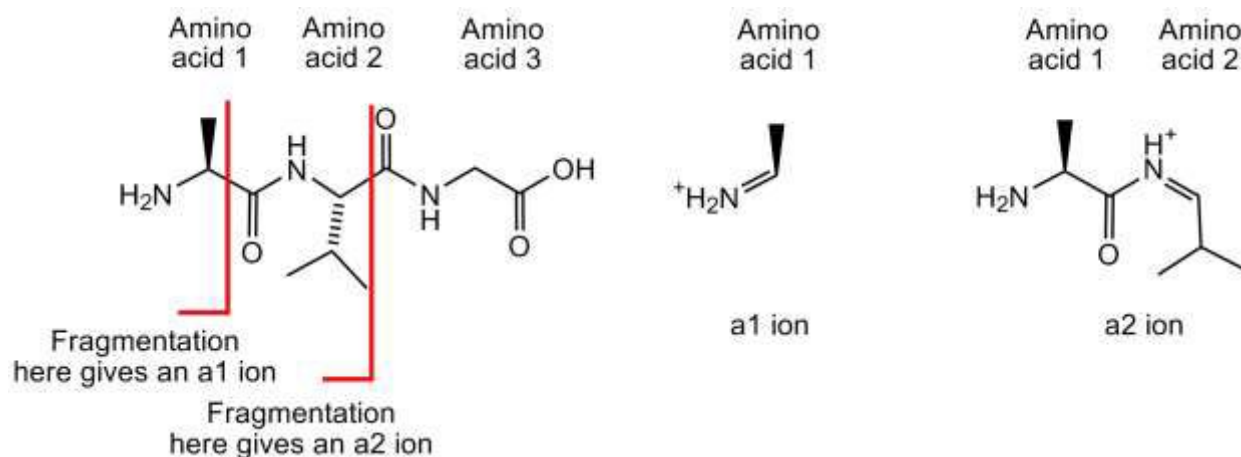

Fossilised bones potentially contain DNA and protein sequences that can be used to infer evolutionary links to modern species. Advances in mass spectrometry have made it possible to get sequence information from subpicomolar quantities of polypeptide, allowing analysis of material obtained from fossils. In reality, fossil polypeptide sequences typically have to be determined from mass-spectra using a combination of database searching and synthetic polypeptide standards. However for some younger fossils, where more material can be extracted, it is possible to determine the polypeptide sequence from the mass spectra once the ions have been identified.

The protein osteocalcin was extracted from a 42000 year old fossil bone found in Juniper Cave, Wyoming, USA.

The MS-MS spectrum of a 19 amino acid polypeptide fragment of this protein is shown below:

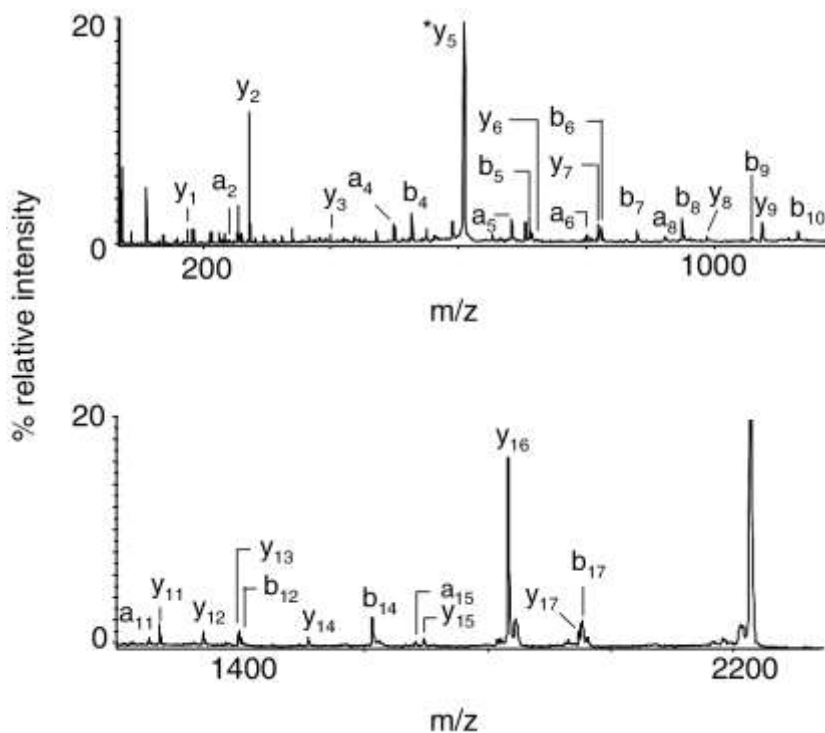

ion	<i>m/z</i>	ion	<i>m/z</i>	ion	<i>m/z</i>	ion	<i>m/z</i>
y ₁	175.1	b ₅	715.3	y ₈	986.5	b ₁₂	1400.7
a ₂	249.1	y ₆	726.4	b ₉	1069.5	y ₁₄	1508.8
y ₂	272.2	a ₆	800.4	y ₉	1083.5	b ₁₄	1612.7
y ₃	401.2	y ₇	823.4	b ₁₀	1140.5	a ₁₅	1681.8
a ₄	501.2	b ₆	828.4	a ₁₁	1209.6	y ₁₅	1694.9
b ₄	529.2	b ₇	885.4	y ₁₁	1267.6	y ₁₆	1831.9
y ₅	611.4	a ₈	928.4	y ₁₂	1338.7	y ₁₇	1946.9
a ₅	687.3	b ₈	956.5	y ₁₃	1395.7	b ₁₇	1951.9

- a) Using the mass spectrum and the table of ion masses determine as far possible the sequence of this polypeptide. Where there is more than one possible amino acid at a position all possibilities should be listed. The first two amino acids in the polypeptide sequence are Tyr-Leu. The polypeptide

sequence also contains the amino acid hydroxyproline, Hyp, which has a mass of 131.1:



Part of the polypeptide sequence of osteocalcin from a number of different modern species are shown below:

Carp	DLTVAQLESLEKEVCEANLACEHMMDVSGIIAAYTAYYGPIPY
Chicken	HYAQDSGVAGAPPNPLEAQREVCELS PDCDELADQIGFQEAYRRFYGPV
Cow	YLDHWLGAPAPYPDPLEPKREVCELN PDCDELADHIGFQEAYRRFYGPV
Horse	YLDHWLGAPAPYPDPLEPRREVCELN PDCDELADHIGFQEAYRRFYGPV
Human	YLYQWLGAPVPYPDPLEPRREVCELN PDCDELADHIGFQEAYRRFYGPV
Rabbit	QLINGQGAPAPYPDPLEPKREVCELN PDCDELADQVGLQDAYQRFYGPV
Sheep	YLDPGLGAPAPYPDPLEPRREVCELN PDCDELADHIGFQEAYRRFYGPV
Toad	SYGNVVGQGAAVGSPLESQREVCELN PDCDELADHIGFQEAYRRFYGPV

Both hydroxyproline and proline are represented by P in the polypeptide sequences shown above.

- b) To which modern species does the protein from the fossil appear to be most closely related?

Problem 29 Creatine kinase

The factors governing energy production in muscle are important in understanding the response of the body to exercise and also in the determination of the physiological effect of cardiac and muscular diseases.

Cells use adenosine triphosphate (ATP) as the molecular energy currency; the hydrolysis of ATP to adenosine diphosphate (ADP) is often coupled with other chemical reactions.

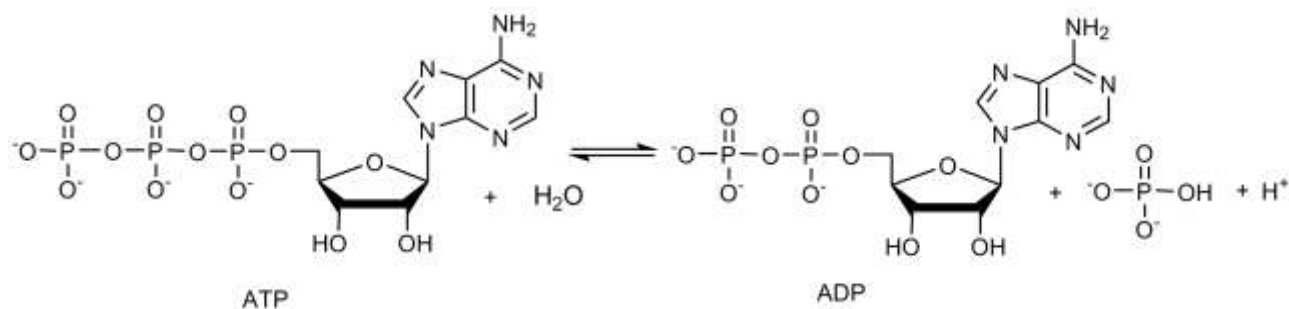

Biochemistry textbooks often represent this reaction as:

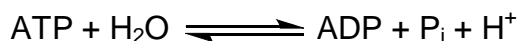

In order to simplify free-energy calculations for biochemical reactions the standard free-energy change at pH 7.0, typically denoted $\Delta_r G^\circ$, is used. The equilibrium constant at pH 7.0 is denoted K' . For the ATP hydrolysis reaction the relation between $\Delta_r G'$ and the concentration of species present will therefore be:

$$\Delta_r G' = \Delta_r G^\circ + RT \ln \left(\frac{[\text{ADP}][\text{P}_i]}{[\text{ATP}]} \right)$$

At 37 °C the value of K' for the hydrolysis of ATP to ADP is 138000.

- a) A 10 mM solution of ATP is prepared in a solution buffered at pH 7.0 at 37 °C. What are the concentrations of ATP, ADP and P_i at equilibrium?
- b) What is the value of $\Delta_r G^\circ$ at 37 °C?

One hypothesis for exhaustion after exercise is that an increase in the concentration of ADP relative to ATP could occur, leading to an increase in the value of $\Delta_r G'$ for ATP hydrolysis below that required for normal cellular metabolism.

The *in vivo* concentration of ATP and P_i can be measured using ^{31}P NMR. Unfortunately the concentration of ADP is too low to be measured using ^{31}P NMR. Instead the concentration of ADP has to be determined indirectly from the ^{31}P NMR measured concentration of phosphocreatine and the value of K' for the enzyme creatine kinase. Creatine kinase catalyses the reaction:



To a good approximation this reaction is at equilibrium in the cell with a K' value of 0.006. It is also known that $([\text{creatine}] + [\text{phosphocreatine}])$ is maintained at $42.5 \times 10^{-3} \text{ mol dm}^{-3}$ in the cell.

The ^{31}P NMR spectrum of a forearm muscle was measured in volunteers after a period of rest and after two different intensities of exercise (squeezing a rubber ball). These spectra were used to calculate the concentration of the following phosphorus species:

Condition	[phosphocreatine] / mol dm ⁻³	[ATP] / mol dm ⁻³	[P _i] / mol dm ⁻³
At rest	38.2×10 ⁻³	8.2×10 ⁻³	4.0×10 ⁻³
Light exercise	20.0×10 ⁻³	8.5×10 ⁻³	22×10 ⁻³
Heavy exercise	10.0×10 ⁻³	7.7×10 ⁻³	35×10 ⁻³

Assuming that the pH of the cell remains constant at pH 7.0 during exercise:

- c) Calculate the concentration of ADP present under each of the three conditions.
- d) Calculate the value of $\Delta_r G'$ for the hydrolysis of ATP under each of the three conditions.
- e) Comment on whether these data support the hypothesis that exhaustion after exercise arises from an increase in the value of $\Delta_r G'$ for ATP hydrolysis.

Appendix

Physical constants

Name	Symbol	Value
Avogadro's constant	N_A	$6.0221 \times 10^{23} \text{ mol}^{-1}$
Boltzmann constant	k_B	$1.3807 \times 10^{-23} \text{ J K}^{-1}$
Gas constant	R	$8.3145 \text{ J K}^{-1} \text{ mol}^{-1}$
Faraday constant	F	96485 C mol^{-1}
Speed of light	c	$2.9979 \times 10^8 \text{ m s}^{-1}$
Planck's constant	h	$6.6261 \times 10^{-34} \text{ J s}$
Standard pressure	p°	10^5 Pa
Atmospheric pressure	p_{atm}	$1.01325 \times 10^5 \text{ Pa}$
Zero of the Celsius scale		273.15 K

Amino acids

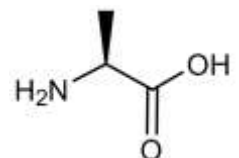
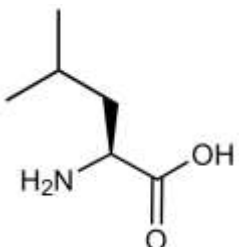
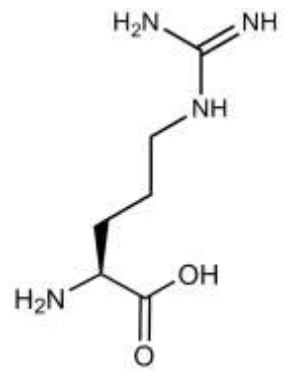
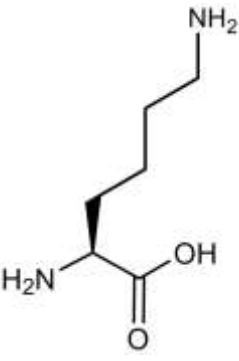
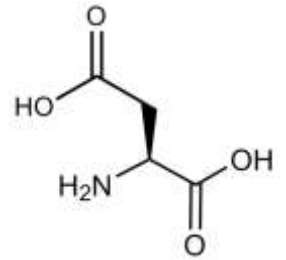
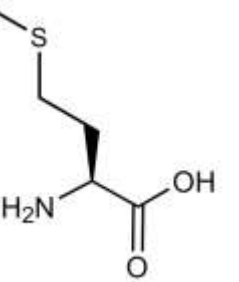
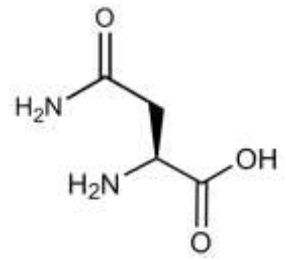
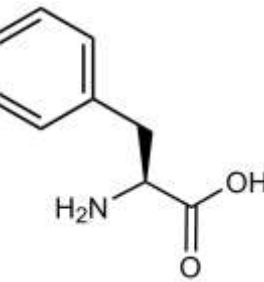
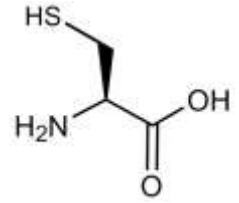
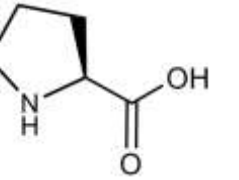
Name	Mass	Structure	Name	Mass	Structure
Alanine Ala A	89.0		Leucine Leu L	131.1	
Arginine Arg R	174.1		Lysine Lys K	146.1	
Aspartic Acid Asp D	133.0		Methionine Met M	149.1	
Asparagine Asn N	132.1		Phenylalanine Phe F	165.1	
Cysteine Cys C	121.0		Proline Pro P	115.1	

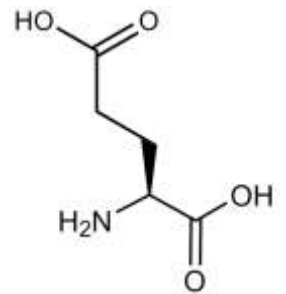
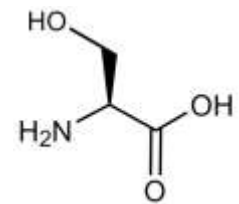
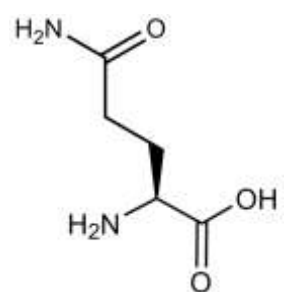
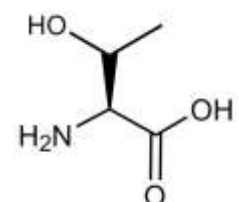
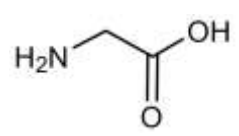
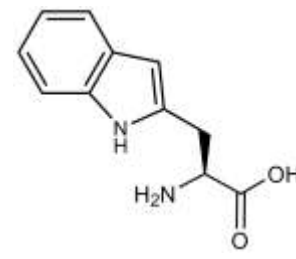
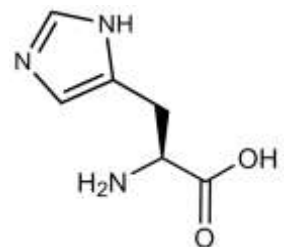
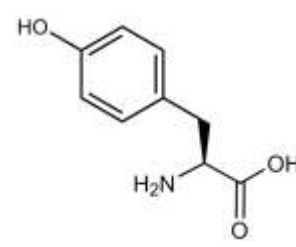
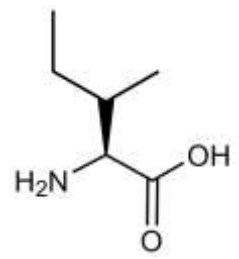
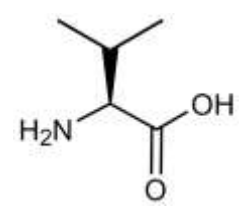
Name	Mass	Structure	Name	Mass	Structure
Glutamic Acid Glu E	147.1		Serine Ser S	105.0	
Glutamine Gln Q	146.1		Threonine Thr T	119.1	
Glycine Gly G	75.0		Tryptophan Trp W	204.1	
Histidine His H	155.1		Tyrosine Tyr Y	181.1	
Isoleucine Ile I	131.1		Valine Val V	117.1	

Masses given are all monoisotopic.

Fields of Advanced Difficulty

Practical

1. Synthetic techniques: filtration, recrystallisation, drying of precipitates, thin layer chromatography.
2. Use of a simple digital conductivity meter.

Safety

The participants of the Olympiad must be prepared to work in a chemical laboratory and be aware of the necessary rules and safety procedures. The organizers will enforce the safety rules given in *Appendix A* of the IChO Regulations during the Olympiad.

The Preparatory Problems are designed to be carried out only in properly equipped chemical laboratories under competent supervision. We did not include specific and detailed safety and disposal instructions as regulations are different in each country. Mentors must carefully adapt the problems accordingly.

The safety (S) and risk (R) phrases associated with the materials used are indicated in the problems. See the Appendix B of the Regulations for the meaning of the phrases. The Regulations are available on our website.

Materials marked with a dagger, †, will not be used at the Olympiad.

Practical problems

Problem P1 The preparation and analysis of polyiodide salts

The propensity for iodine to catenate is well illustrated by the numerous polyiodides, which crystallise from solutions containing iodide ions and iodine. The stoichiometry of the crystals and the detailed geometry of the polyhalide depend very sensitively on the relative concentrations of the components and the nature of the cation.

In this experiment, you will generate and crystallise a quaternary ammonium polyiodide salt of the form $\text{Me}_4\text{N}^+\text{I}_n^-$ ($n = 3, 5$ or 7) and then titrate the amount of iodine in the anion using sodium thiosulphate. From the results of this analysis, you can determine which anion is present in your salt.

Experimental

Two salts, **A** and **B**, of different composition may be prepared by using different quantities of starting materials, as shown below. You can carry out the experiment for either one or both.

	Salt A	Salt B
mass of NMe_4I / g	1.00	0.50
mass of iodine / g	1.26	1.26

Preparation

1. Add the iodine to a 100 cm^3 beaker containing 25 cm^3 ethanol and a magnetic bar. Heat and stir the solution until all the iodine has dissolved, then add the tetramethylammonium iodide. Continue to stir with moderate heating until no white solid remains. Do not allow the solution to boil at any time.
2. Allow the solution to cool slowly to room temperature and finally in an ice bath over about 15 – 20 minutes.
3. Collect the product under suction (Hirsch funnel) and wash on the filter with cold ethanol (10 cm^3) followed by ether (10 cm^3) using a disposable pipette.

4. Allow the product to dry on the filter for several minutes, and then transfer the crystals onto a filter paper. Place into a desiccator and leave under vacuum to dry.

Analysis

5. Weigh approximately 0.5g of the product onto a weighing boat using a four decimal place balance. Record the weight accurately.

6. Using a distilled water wash-bottle, carefully transfer *all* the weighed product into a 250 cm³ bottle.

7. Add approximately 25 cm³ of dichloromethane, replace the stopper and shake to extract the iodine into the organic layer.

8. Fill a 50 cm³ burette with sodium thiosulfate (0.100M) using a small glass funnel.

9. Remove the funnel and titrate the iodine by running small quantities of the sodium thiosulfate from the burette and then replacing the stopper and shaking the bottle.

10. The end-point is very sharp and is given by the removal of all iodine colour from the dichloromethane.

Questions

From the results of the titrations, calculate the formulae of the salts **A** and **B**. What are the shapes of the anions?

Substance		R phrases	S phrases
tetramethylammonium iodide	solid	36/37/38	26-36
iodine	solid	20/21-50	23-25-61
sodium thiosulfate	0.1 M solution	36/37/38	24/25
dichloromethane	liquid	40	23-24/25-36/37

Problem P2 The Williamson Synthesis of Ethers

Symmetrical aliphatic ethers may be prepared from the simpler primary and secondary alcohols by heating with sulphuric acid, but dehydration to the alkene is an important competing reaction. The sulphuric acid process is unsuited to the preparation of ethers from tertiary alcohols and of unsymmetrical ethers.

The Williamson synthesis, using an alkyl halide and a metal alkoxide, is of broader scope and can be used to obtain symmetrical or unsymmetrical ethers. For the latter type, either of two combinations of reactants is possible.

The proper choice depends mainly upon the structure of the alkyl halides involved. Competition arises between the substitution reaction (S_N2) to an ether ($1^\circ > 2^\circ \gg 3^\circ$ halides) and the elimination of HX to form an alkene ($3^\circ \gg 2^\circ > 1^\circ$ halides). Therefore 3° halides are not suitable for the reaction, but ethers having a 3° alkyl group can be prepared from a 3° alkoxide and a 1° halide.

The Williamson synthesis is an excellent method for the preparation of alkylaryl ethers – 1° and 2° alkyl halides react readily with sodium or potassium phenoxides.

In this experiment benzyl chloride is reacted with 4-chlorophenol under basic conditions to produce an ether.

The use of a fume cupboard protective clothing including gloves is essential for this experiment.

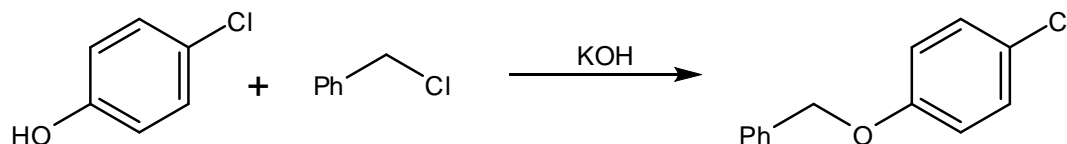

Experimental

Add absolute ethanol (50 cm^3) to potassium hydroxide pellets (0.87g) in a 100 cm^3 round bottomed flask with a ground-glass joint.

Add 4-Chlorophenol (2g) followed by benzyl chloride (1.8 cm^3) and lithium iodide (approx. 20 mg - the end of a micro-spatula).

Add a boiling stick, fit the flask with a condenser and heat under gentle reflux for 1 hour (an isomantle is recommended but keep careful control of the heating to maintain gentle reflux otherwise vigorous bumping can occur).

Allow the reaction mixture to cool and pour onto ice/water (150 cm³) with swirling. Isolate the crude product by suction filtration and wash with ice-cold water (3 x 10 cm³). Press dry on the filter.

The crude product should be recrystallised from *aqueous ethanol*. This entails dissolving your compound in the minimum volume of boiling ethanol and then adding water dropwise until the first crystals appear. Then set the hot solution aside to cool in the usual manner.

Record the yield of your product and run a thin layer chromatogram on a silica plate using ether/petroleum ether 2:8 as the eluent. Record the R_f value. Measure and record the m.p.

Questions

1. What is the role of the lithium iodide added to the reaction mixture?
2. Substantial increases in the rate of reaction are often observed if S_N2 reactions are carried out in solvents such as dimethylformamide (DMF) or dimethylsulphoxide (DMSO). Suggest why this is so.

Substance		R phrases	S phrases
benzyl chloride †	liquid	45-22-23-37/38-48/22-41	53-45
4-chlorophenol	solid	20/21/22-51/53	28-61
potassium hydroxide	solid	22-34-35	26-36/37/39-45
lithium iodide	solid	36/37/38-61	22-26-45-36/37/39-53
diethyl ether	liquid	12-19-66-67	9-16-29-33
petroleum ether †	liquid	45-22	53-45

† This compound will not be used at the Olympiad

Problem P3 Selective Reduction of a Highly Unsaturated Imine

Sodium borohydride is a selective reducing agent. In this experiment you will condense 3-nitroaniline with cinnamaldehyde to produce the highly unsaturated intermediate **A** (an imine). This is then selectively reduced with sodium borohydride to produce **B**. The structure of **B** can be deduced from the ^1H NMR spectrum.

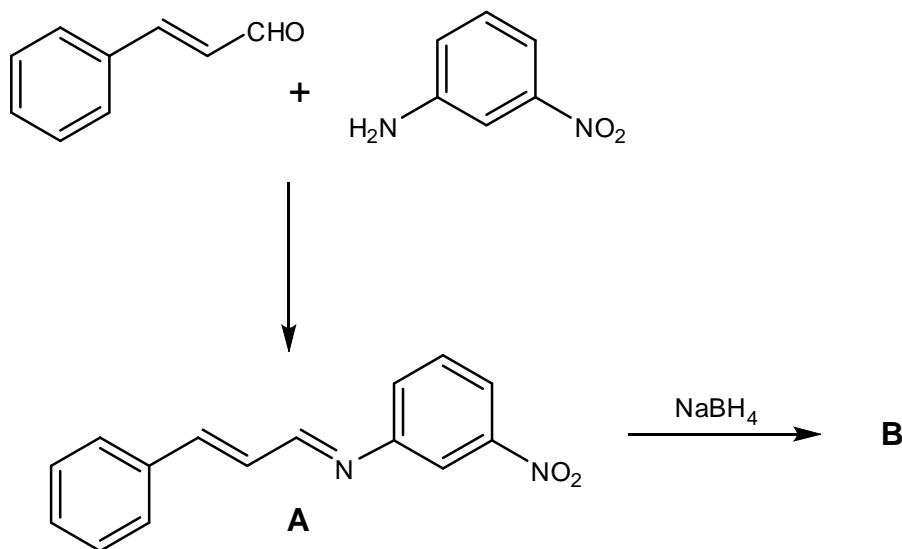

The experiment illustrates the classic method of imine formation (azeotropic removal of water).

Experimental

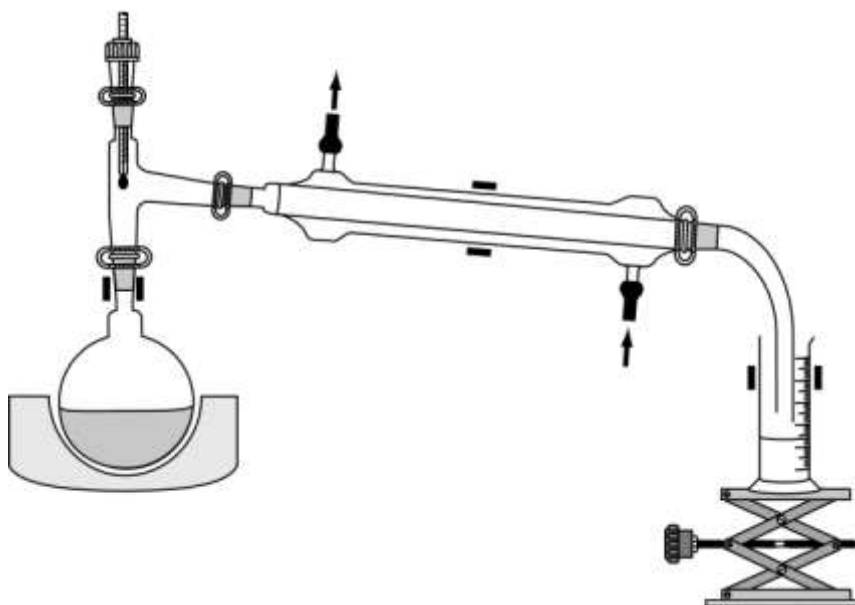

Place 3-Nitroaniline (2.76 g) and absolute ethanol (20 cm^3) in a 100 cm^3 round bottomed flask, together with a few anti-bumping granules. Set up the flask for

distillation as shown above using an isomantle or steam bath as the heat source. Use a graduated measuring cylinder to collect the distillate.

Add dropwise a solution of cinnamaldehyde (2.9 g) in absolute ethanol (5 cm³) through the thermometer inlet. Turn on the heat source and distil off approx. 22 cm³ of solvent over a period of about 30 minutes. During the distillation dissolve with stirring sodium borohydride (0.76 g) in 95% ethanol (20 cm³).

After the 22 cm³ of solvent has distilled off, disconnect the apparatus. Set aside a small sample of the residue **A** which remains in the flask for thin layer chromatography. Then add 95 % ethanol (20 cm³) to the flask to dissolve the remaining residue. To this solution of **A** add VERY CAREFULLY the sodium borohydride solution. This must be added slowly and with constant swirling of the reaction flask (vigorous effervescence occurs). After the addition, heat the mixture under reflux for 15 minutes, then cool the flask and pour the contents into water (50 cm³). The product **B**, should crystallise out slowly on standing in an ice bath. Recrystallise your product from 95% ethanol.

Record the yield of your product. Run a thin layer chromatogram of your product **B** and the sample of **A** on a silica plate using hexane/ethyl acetate 1:1 as the eluent. Record the R_f value of each. Measure and record the m.p. of **B**. Predict the structure of **B** using the ¹H NMR spectrum given below.

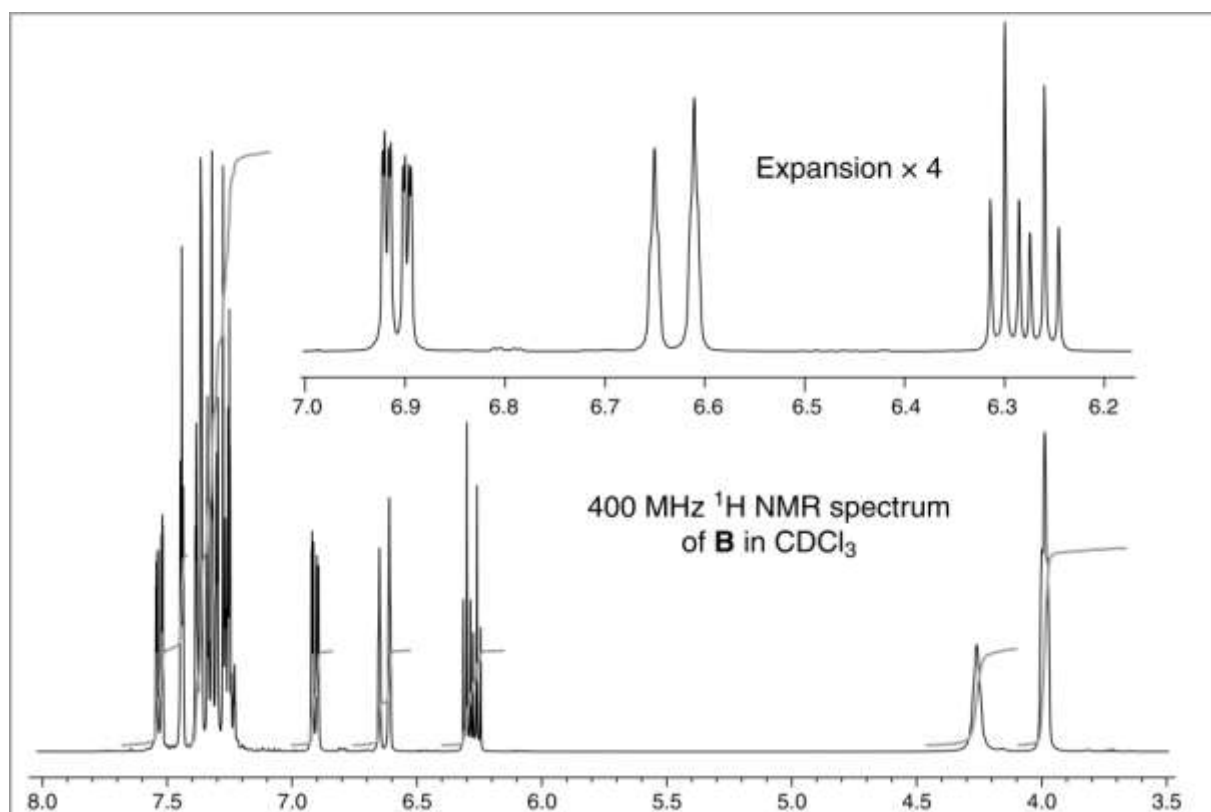

Questions

In the preparation of **A** why is *absolute* ethanol and not 95% used? Why is the solvent removed during the reaction?

Substance		R phrases	S phrases
3-nitroaniline	solid	33-23/24/25-52/53	28-45-36/37-61
cinnamaldehyde	liquid	41	26-39
sodium borohydride	solid	25-34-43	26-27-28-45-36/37/39
hexane	liquid	11-38-48/20-51/53-62-65-67	9-16-29-33-36/37-61-62
ethyl acetate	liquid	11-36-66-67	16-26-33

Problem P4 A Simple Aldol Codensation

The Claisen-Schmidt reaction involves the synthesis of an α,β -unsaturated ketone by the condensation of an aromatic aldehyde with a ketone. The aromatic aldehyde possesses no hydrogens α -to the carbonyl group, it cannot therefore undergo self condensation but reacts rapidly with the ketone present.

The initial aldol adduct cannot be isolated as it dehydrates readily under the reaction conditions to give an α,β -unsaturated ketone. This unsaturated ketone also possesses activated hydrogens α -to a carbonyl group and may condense with another molecule of the aldehyde.

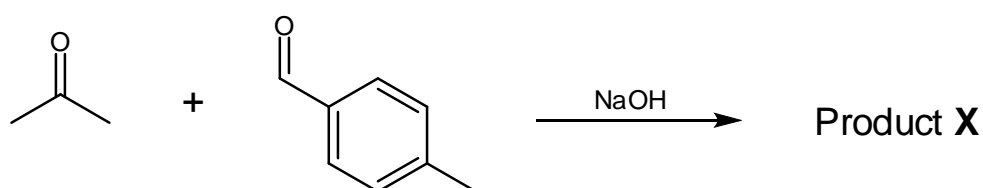

In this experiment you will carry out the base catalysed aldol condensation of *p*-tolualdehyde with acetone. The product will be purified by recrystallisation and its structure determined using the spectra provided.

Experimental

Dissolve *p*-tolualdehyde (2.5 cm³) and acetone (1 cm³) in ethanol (25 cm³) contained in a stoppered flask. Add bench sodium hydroxide solution (5 cm³ of aqueous 10%) and water (20 cm³). Stopper the flask and shake it for 10 minutes, releasing the pressure from time to time. Allow the reaction mixture to stand for 5-10 minutes with occasional shaking and then cool in an ice bath. Collect the product by suction filtration, wash it well on the filter with cold water and recrystallise from ethanol.

Record the yield of your product. Run a thin layer chromatogram on a silica plate using ether/petroleum ether 2:8 as the eluent and record the *R_f* value of the product. Measure and record the m.p. of **X**.

Elemental analysis of **X** reveals it to have 88.99% carbon and 6.92% hydrogen. Use this information together with the NMR spectra to suggest a structure for **X**.

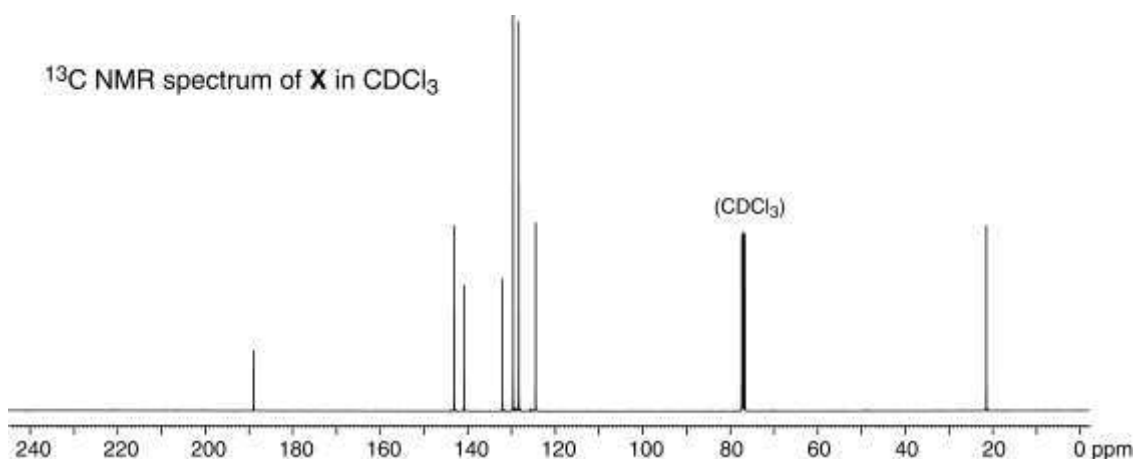
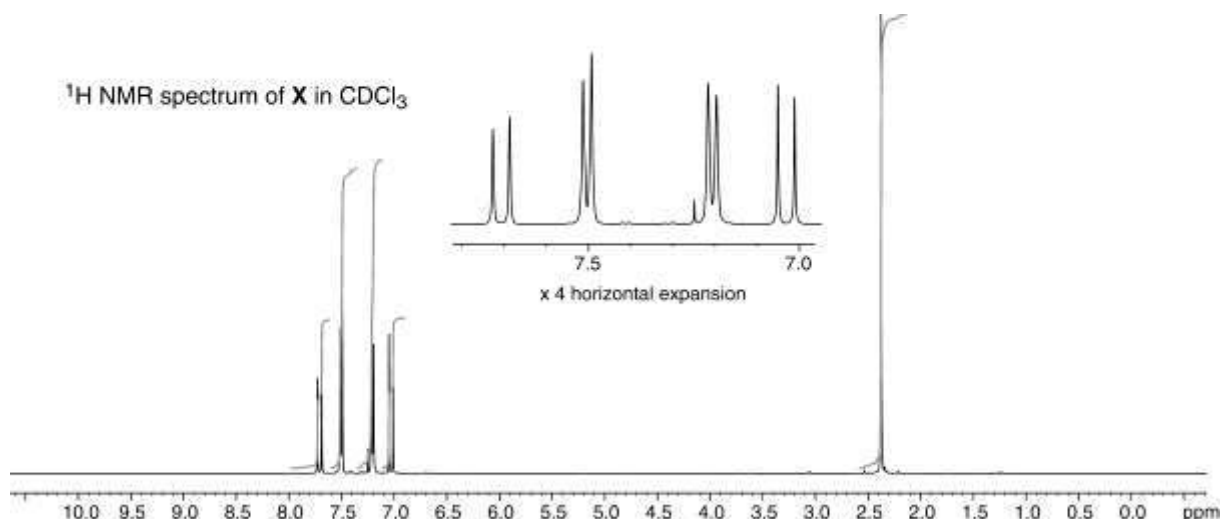

Substance		R phrases	S phrases
<i>p</i> -tolualdehyde	solid	22-36/37/38	26-36
acetone	liquid	11-36-66-67	9-16-26
sodium hydroxide	10% aq. solution	36/38	26
diethyl ether	liquid	12-19-66-67	9-16-29-33
petroleum ether †	liquid	45-22	53-45

† This compound will not be used at the Olympiad

Problem P5 The Menshutkin Reaction

The nucleophilic substitution reaction between a tertiary amine and an alkyl halide is known as the Menshutkin reaction. This experiment investigates the rate law for the reaction between the amine known as DABCO (1,4-diazabicyclo[2.2.2]octane) and benzyl bromide:

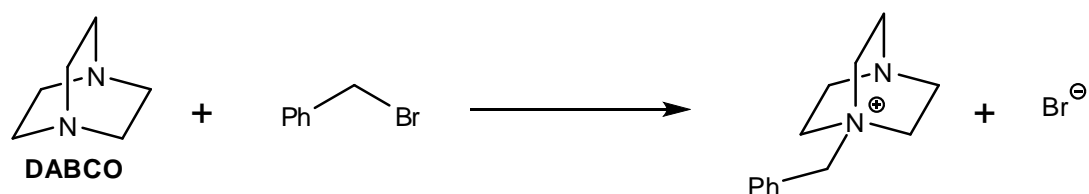

It is possible for the second nitrogen in the DABCO molecule to react with a second benzyl bromide. However, in this experiment the DABCO will always be in excess so further reaction is unlikely. The reaction could proceed by either the S_N1 or the S_N2 mechanism. In this experiment, you will confirm that the order with respect to benzyl bromide is 1 and determine the order with respect to DABCO. This should enable you to distinguish between the two possible mechanisms.

As the reaction proceeds neutral species, DABCO and benzyl bromide, are replaced by charged species, the quaternary ammonium ion and Br^- . Therefore the electrical conductivity of the reaction mixture increases as the reaction proceeds and

so the progress of the reaction can be followed by measuring the electrical conductivity as a function of time.

Benzyl bromide is a lacrymator. This experiment should be performed in a fume cupboard.

The Method in Principle

The rate law for the reaction can be written as

$$\frac{d[\text{Br}^-]}{dt} = k[\text{RBr}][\text{DABCO}]^\alpha \quad [1]$$

where we have assumed that the order with respect to the benzyl bromide, RBr, is 1 and the order with respect to DABCO is α .

In the experiment, the concentration of DABCO is in excess and so does not change significantly during the course of the reaction. The term $k[\text{DABCO}]^\alpha$ on the right-hand side of Eqn. [1] is thus effectively a constant and so the rate law can be written

$$\frac{d[\text{Br}^-]}{dt} = k_{\text{app}}[\text{RBr}] \quad \text{where } k_{\text{app}} = k[\text{DABCO}]^\alpha \quad [2]$$

k_{app} is the apparent first order rate constant under these conditions; it is not really a rate "constant", as it depends on the concentration of DABCO.

To find the order with respect to DABCO we measure k_{app} for reaction mixtures with different excess concentrations of DABCO. From Eqn. [2], and taking logs, we find

$$\ln k_{\text{app}} = \ln k + \alpha \ln[\text{DABCO}] \quad [3]$$

So a plot of $\ln k_{\text{app}}$ against $\ln[\text{DABCO}]$ should give a straight line of slope α .

k_{app} may be found by measuring the conductance at time t , $G(t)$, and at time infinity, G_∞ . In the supplementary material it is shown that a graph of $\ln[G_\infty - G(t)]$ against t should be a straight line with slope k_{app} .

In practice it is rather inconvenient to measure conductance at time infinity but this can be avoided by analysing the data using the *Guggenheim method*. In this method each reading of the conductance at time t , is paired up with another at time $t + \Delta$, $G(t+\Delta)$, where Δ is a fixed time interval that needs to be at least a half-life. As shown in the supplementary material, a plot of $\ln[G(t+\Delta) - G(t)]$ against time should be a straight line of slope $-k_{\text{app}}$. For example, suppose we take measurements at fixed

regular intervals, say each 30 s and choose an appropriate value of Δ , say 3 minutes (180 s). The plot made is of the points $\{x,y\} = \{0, \ln[G(180)-G(0)]\}$, $\{30, \ln[G(210)-G(30)]\}$, $\{60, \ln[G(240)-G(60)]\}$, ...

The Apparatus

Cheap conductivity meters are commercially available, for example the Primo5 conductivity stick meter from Hanna instruments works well with this practical. These simply dip into the solution and the conductance of the solution can be read off the digital display.

www.hannainst.co.uk/product/PRIMO5-Conductivity-stick-meter/PRIMO5/

Procedure

You are provided with the following solutions, all in ethanol: 0.15, 0.20 and 0.25 mol dm⁻³ DABCO, and approx. 0.6 mol dm⁻³ benzyl bromide (this must be freshly made up). You should measure k_{app} for each of these solutions by measuring the conductance as a function of time and then analysing the data using the Guggenheim method. From the three values of k_{app} , the order with respect to DABCO can be found by plotting $\ln k_{app}$ against $\ln [DABCO]$, as shown by Eqn. [3].

Ideally we ought to keep the reagents and the reaction mixture in a thermostat. However, as the heat evolved is rather small, the temperature will remain sufficiently constant for our purposes.

Kinetic Runs

1. Rinse the conductivity dipping electrode with ethanol from a wash bottle, catching the waste in a beaker. Allow the excess ethanol to drain off and gently dry the electrode with tissue.
2. Transfer 10 cm³ of the DABCO solution to a clean dry boiling tube.
3. Add 100 μ l of the benzyl bromide solution.
4. Insert and withdraw the dipping electrode of the conductance meter a few times in order to mix the solution and then, with the electrode in place, start the stop-watch.
5. Record the conductance at 30 second intervals (it is essential to make the measurements at regular intervals), starting with the first reading at 30 seconds and continuing until there is no further significant change in the conductance, or for 10 minutes, whichever is the shorter time.
6. *From time to time, gently* lift the electrode in and out so as to stir the solution.

7. Once the measurements have been made, remove the electrode, discard the solution and clean the electrode as in step 1.
8. Make the measurements for the 0.15 mol dm⁻³ solution of DABCO, and then for the 0.20 and 0.25 mol dm⁻³ solutions.

Data Analysis

For each run determine k_{app} using the Guggenheim method – three minutes is about right for the fixed interval Δ . Then plot $\ln k_{\text{app}}$ against $\ln [\text{DABCO}]$ and hence determine the order with respect to DABCO.

Substance		R phrases	S phrases
DABCO	0.15, 0.20 and 0.25 M solutions in ethanol	11-22-36/37/38	26-37
benzyl bromide	0.6 M solution in ethanol	36/37/38	26-39

Supplementary information

The key to this experiment is how to use the measured conductance of the reaction mixture to determine the first order rate constant, k_{app} . The first stage is simply to integrate the rate law; to do this we note that for each benzyl bromide molecule that reacts one bromide ion is generated so that at any time $[\text{Br}^-] = [\text{RBr}]_{\text{init}} - [\text{RBr}]$, where $[\text{RBr}]_{\text{init}}$ is the initial concentration of benzyl bromide. Thus the rate equation can be written in terms of $[\text{Br}^-]$ by putting $[\text{RBr}] = [\text{RBr}]_{\text{init}} - [\text{Br}^-]$; integration is then straightforward:

$$\frac{d[\text{Br}^-]}{dt} = k_{\text{app}}([\text{RBr}]_{\text{init}} - [\text{Br}^-])$$

$$\int \frac{d[\text{Br}^-]}{([\text{RBr}]_{\text{init}} - [\text{Br}^-])} = \int k_{\text{app}} dt$$

i.e. $-\ln([\text{RBr}]_{\text{init}} - [\text{Br}^-]) = k_{\text{app}}t + \text{const.}$

The constant can be found by saying that at time zero, $[\text{Br}^-] = 0$, hence

$$-\ln([\text{RBr}]_{\text{init}}) = \text{const.}$$

$$\text{hence } -\ln\left([\text{RBr}]_{\text{init}} - [\text{Br}^-]\right) = k_{\text{app}}t - \ln([\text{RBr}]_{\text{init}})$$

which can be written

$$[\text{Br}^-] = [\text{RBr}]_{\text{init}}(1 - \exp[-k_{\text{app}}t]) \quad [4]$$

When the reaction has gone to completion, at time infinity, the concentration of bromide is equal to the initial concentration of RBr so Eqn. [4] can be written

$$[\text{Br}^-] = [\text{Br}^-]_{\infty}(1 - \exp[-k_{\text{app}}t]) \quad [5]$$

where $[\text{Br}^-]_{\infty}$ is the concentration of Br^- at time infinity. Equation [5] says that the concentration of Br^- approaches a limiting value of $[\text{Br}^-]_{\infty}$ with an exponential law. A similar relationship can be written for the other product, the quaternary ammonium ion, whose concentration will be written $[\text{R}_4\text{Br}^+]$.

$$[\text{R}_4\text{Br}^+] = [\text{R}_4\text{Br}^+]_{\infty}(1 - \exp[-k_{\text{app}}t]) \quad [6]$$

We will assume that the conductance of the reaction mixture, G , is proportional to the concentration of the charged species present:

$$G = \lambda_{\text{Br}^-}[\text{Br}^-] + \lambda_{\text{R}_4\text{N}^+}[\text{R}_4\text{N}^+]$$

where λ are simply the constants of proportionality.

Using Eqns. [5] and [6] to substitute for the concentration of Br^- and R_4N^+ we find

$$\begin{aligned} G &= \lambda_{\text{Br}^-} \left\{ [\text{Br}^-]_{\infty}(1 - \exp[-k_{\text{app}}t]) \right\} + \lambda_{\text{R}_4\text{N}^+} \left\{ [\text{R}_4\text{Br}^+]_{\infty}(1 - \exp[-k_{\text{app}}t]) \right\} \\ &= \left(\lambda_{\text{Br}^-} [\text{Br}^-]_{\infty} + \lambda_{\text{R}_4\text{N}^+} [\text{R}_4\text{Br}^+]_{\infty} \right) (1 - \exp[-k_{\text{app}}t]) \\ &= G_{\infty}(1 - \exp[-k_{\text{app}}t]) \end{aligned} \quad [7]$$

where we have recognised that $\left(\lambda_{\text{Br}^-} [\text{Br}^-]_{\infty} + \lambda_{\text{R}_4\text{N}^+} [\text{R}_4\text{Br}^+]_{\infty} \right)$ is the conductance at time infinity, G_{∞} .

Equation [7] can be rearranged to give a straight line plot:

$$1 - \frac{G}{G_{\infty}} = \exp[-k_{\text{app}}t]$$

$$\ln\left(1 - \frac{G}{G_\infty}\right) = -k_{\text{app}}t \quad \text{or} \quad \ln\left(\frac{G_\infty - G}{G_\infty}\right) = -k_{\text{app}}t$$

$$\text{or} \quad \ln(G_\infty - G) = -k_{\text{app}}t + \ln G_\infty$$

Hence a plot of $\ln(G_\infty - G)$ against t should be a straight line with slope k_{app} .

The Guggenheim Method

From Eqn. [9] the conductance at time t , $G(t)$, can be written

$$G(t) = G_\infty(1 - \exp[-k_{\text{app}}t])$$

At some time $(t + \Delta)$ later the conductance is $G(t + \Delta)$

$$G(t + \Delta) = G_\infty(1 - \exp[-k_{\text{app}}(t + \Delta)])$$

The difference $G(t + \Delta) - G(t)$ is

$$\begin{aligned} G(t + \Delta) - G(t) &= G_\infty(1 - \exp[-k_{\text{app}}(t + \Delta)] - 1 + \exp[-k_{\text{app}}t]) \\ &= G_\infty(\exp[-k_{\text{app}}t] - \exp[-k_{\text{app}}(t + \Delta)]) \\ &= G_\infty \exp[-k_{\text{app}}t](1 - \exp[-k_{\text{app}}\Delta]) \end{aligned}$$

Taking logarithms of both sides gives, from the last line,

$$\ln(G(t + \Delta) - G(t)) = \ln G_\infty - k_{\text{app}}t + \ln(1 - \exp[-k_{\text{app}}\Delta])$$

This implies that a plot of $\ln(G(t + \Delta) - G(t))$ against time should be a straight line of slope $-k_{\text{app}}$; to make this plot there is no need to know the value of the conductance at infinite time, G_∞ , and this is the main advantage of the Guggenheim method.