

Problem 1

a) The enthalpy of combustion (ΔH°) and the standard enthalpy of formation (ΔH_f°) of a fuel can be determined by measuring the temperature change in a calorimeter when a weighed amount of the fuel is burned in oxygen.

- (i) Suppose 0.542 g of isooctane is placed in a fixed-volume (“bomb”) calorimeter, which contains 750 g of water initially at 25.000°C surrounding the reaction compartment. The heat capacity of the calorimeter itself (excluding the water) has been measured in a separate calibration to be 48 JK⁻¹. After the combustion of the isooctane is complete, the water temperature is measured to be 33.220°C. Taking the specific heat of water to be 4.184 J g⁻¹ K⁻¹ calculate ΔU° (the internal energy change) for the combustion of 0.542 g of isooctane.
- (ii) Calculate ΔU° for the combustion of 1 mol of isooctane.
- (iii) Calculate ΔH° for the combustion of 1 mol of isooctane.
- (iv) Calculate ΔH_f° for the isooctane.

The standard enthalpy of formation of CO₂(g) and H₂O(l) are -393.51 and -285.83 kJ mol⁻¹, respectively. The gas constant, R, is 8.314 J. K⁻¹ mol⁻¹.

b) The equilibrium constant (K_c) for an association reaction

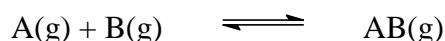

is 1.80 x 10³ L mol⁻¹ at 25°C and 3.45 x 10³ L mol⁻¹ at 40°C.

- (i) Assuming ΔH° to be independent of temperature, calculate ΔH° and ΔS° .
- (ii) Calculate the equilibrium constants K_p and K_x at 298.15 K and a total pressure of 1 atm.

(The symbols K_c , K_p and K_x are the equilibrium constants in terms of concentrations, pressure and mole fractions, respectively.)

c) Although iodine is not very soluble in pure water, it can dissolve in water that contains I⁻(aq) ion,



The equilibrium constant of this reaction is measured as a function of temperature with these results:

Temperature (°C)	:	15.2	25.0	34.9
Equilibrium constant	:	840	690	530

Estimate the ΔH° of this reaction.

Problem 2

a) Acetone (denoted as A) and chloroform (denoted as C) are miscible at all proportions. The partial pressure of acetone and chloroform have been measured at 35°C for the following solutions:

X_C	0.00	0.20	0.40	0.60	0.80	1.00
P_C (torr)	0.00	35	82	142	219	293
P_A (torr)	347	270	185	102	37	0.00

where X_C is the mole fraction of chloroform in the solution.

- Show that the solutions are non-ideal solutions.
- The deviation from ideal behavior can be expressed as being positive or negative deviation. Which deviation do the solutions exhibit?
- Non-ideal behaviour can be expressed quantitatively in terms of activity of each component in the solution. Activity (a) may be found from the following equation (taking chloroform as an example):

$a_c = P_c / P_c^o$, where a_c is the activity of chloroform and P_c^o is the vapour pressure of pure chloroform.

Calculate the activity of chloroform and acetone for each solution.

b)

- Find the value of K_f (the freezing-point depression or cryoscopic constant) for the solvent, *p*-dichlorobenzene, from the following data:

Molar Mass	Melting Point (K)	ΔH_{fus}^o (kJ mol ⁻¹)	
<i>p</i> -dichlorobenzene	147.01	326.28	17.88

- A solution contains 1.50 g of nonvolatile solute in 30.0 g *p*-dichlorobenzene and its freezing point is 323.78 K. Calculate the molar mass of the solute.
- Calculate the solubility for the ideal solution of *p*-dichlorobenzene at 298.15 K.

Problem 3

a) The natural decay chain ${}^{238}_{92}\text{U} \longrightarrow {}^{206}_{82}\text{Pb}$ consists of several alpha and beta decays in a series of consecutive steps

- The first two steps involve ${}^{234}_{90}\text{Th}$ ($t_{1/2} = 24.10$ days) and ${}^{234}_{91}\text{Pa}$ ($t_{1/2} = 6.66$ hours). Write nuclear equations for the first two steps in the decay of ${}^{238}\text{U}$ and find the total kinetic energy in MeV carried off by the decay products. The atomic masses are: ${}^{238}\text{U} = 238.05079$ u, ${}^{234}\text{Th} = 234.04360$ u, ${}^{234}\text{Pa} = 234.04332$ u, and ${}^4\text{He} = 4.00260$ u; 1 u = 931.5 MeV

- (ii) The subsequent decays of ^{238}U lead to $^{226}_{88}\text{Ra}$ ($t_{1/2} = 1620$ years) which, in turn, emits an alpha particle to form ^{222}Rn ($t_{1/2} = 3.83$ days). If a molar volume of radon under this condition is 25.0 L, what volume of radon is in a secular equilibrium with 1.00 kg of radium?
- (iii) The activity of a radioactive sample of one member of the ^{238}U series decreases by a factor of 10 in 12.80 days, find the decay constant and its half-life.
- b) In the neutron induced binary fission of $^{235}_{92}\text{U}$, two stable end products $^{98}_{42}\text{Mo}$ and $^{136}_{54}\text{Xe}$ are often found. Assuming that these nuclides have come from the original fission process, find
- what elementary particles are released,
 - energy released per fission in MeV and in joules,
 - energy released per 1 gram of ^{235}U in unit of kW-hour.
- Atomic masses: $^{235}_{92}\text{U} = 235.04393$ u, $^{136}_{54}\text{Xe} = 135.90722$ u,
 $^{98}_{42}\text{Mo} = 97.90551$ u, and
 $m_{\text{n}} = 1.00867$ u, $1 \text{ MeV} = 1.602 \times 10^{-13} \text{ J}$.

Problem 4

The following reaction is studied at 25°C in benzene solution containing 0.1 M pyridine:

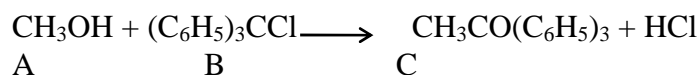

The following sets of data are observed.

	Initial concentrations			Δt Min	Final concentration M
	$[\text{A}]_0, \text{M}$	$[\text{B}]_0, \text{M}$	$[\text{C}]_0, \text{M}$		
(1)	0.100	0.0500	0.0000	25.0	0.00330
(2)	0.100	0.100	0.0000	15.0	0.00390
(3)	0.200	0.100	0.0000	7.50	0.00770

- What rate law is consistent with the above data?
- What is the average value for the rate constant, expressed in seconds and molar concentration units?

Problem 5

Reaction between hypochlorite and iodide ions in the presence of basic solution is as follow:



with the experimental rate equation:

$$\text{Rate} = k \frac{[\text{I}^-][\text{OCl}^-]}{[\text{OH}^-]}$$

Three possible mechanisms are shown below

Mechanism I



Mechanism II

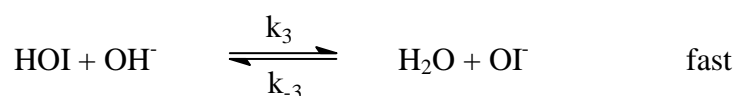

Mechanism III

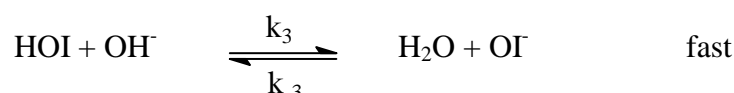
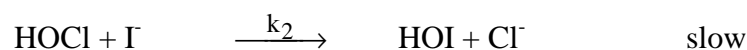
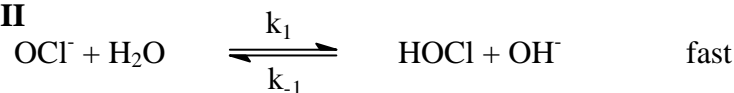

- Which of the above mechanisms is the most appropriate for the observed kinetic behaviour by applying steady state approximation?
- What are the rate constant, frequency factor and activation energy of the overall reaction consistent with the mechanism in (i)?
- What is the order of the reaction in a buffer solution?
- Show that the hydronium ions catalyze the reaction above.
- Show that the catalytic rate constant in (iv) depends upon pH.

Problem 6

a) Cystine ($\text{C}_6\text{H}_{12}\text{N}_2\text{O}_4\text{S}_2$) is a diamino-dicarboxylic acid which is a dimer of L-cysteine. The dimer can be cleaved by treatment with a thiol such as mercaptoethanol ($\text{HOCH}_2\text{CH}_2\text{SH}$) to give L-cysteine ($\text{C}_3\text{H}_7\text{NO}_2\text{S}$).

- Write the structural formula of cystine with absolute configuration.
- What is the role of mercaptoethanol in this reaction?

Cysteine (1 mol) can also be cleaved by treatment with performic acid, HCOO_2H , to cysteic acid, $\text{C}_3\text{H}_7\text{NO}_5\text{S}$ (2 mols) which is a strong acid.

- Write the structure of cysteic acid at isoelectric point.
- When a peptide consisting two chains, A and B, linked by a single disulfide bond between two cysteine residues in each chain is treated with performic

acid, two modified peptides, A' and B' which have net charges +5 and -3 respectively are produced at pH 7.0. Calculate the net charge of the original peptide at the same pH.

b) When peptide C (MW 464.5) is completely hydrolysed by aqueous HCl, equimolar quantities of glycine (Gly), phenylalanine (Phe), aspartic acid (Asp), glutamic acid (Glu) and one equivalent of ammonia (NH₃) are detected in the hydrolysate.

On treatment of C with enzyme carboxypeptidase, glutamic acid and a tripeptide are obtained. Partial acid hydrolysis of the tripeptide gives a mixture of products, two of which are identified as glycylaspartic acid (Gly-Asp) and aspartylphenylalanine (Asp-Phe).

- From the above information, deduce a complete sequence of peptide C.
- What is the approximate isoelectric point of peptide C (pH < 7, ≈ 7, > 7).

Problem 7

a) Suggest the possible cyclic structure(s) with stereochemistry of (D)-Tagalose in solution using Harworth projection.

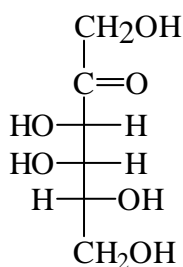

(D)-tagalose

b) Two products with the same molecular formula C₆H₁₀O₆ are obtained when D-arabinose is treated with sodium cyanide in acidic medium followed by an acidic hydrolysis.

Write possible structures with stereochemistry for these two compounds and how do they formed?

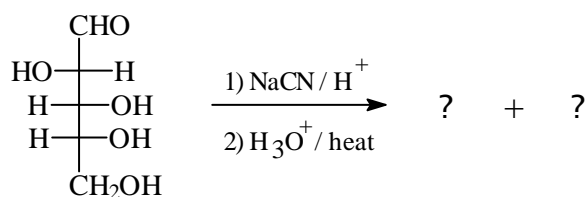

(D)-arabinose

c) When a reducing disaccharide, turanose, is subjected to a hydrolysis, D-glucose and D-fructose are obtained in equal molar as the saccharide used. Methylation of turanose with methyl iodide in the presence of silver oxide followed by a hydrolysis yielded 2,3,4,6-tetra-O-methyl-D-fructose.

Propose the possible structure for turanose, the stereochemistry at the anomeric position(s) is not required.

Problem 8

a) Show how the following labeled compounds can be synthesized, using any organic starting materials as long as they are unlabeled at the start of your synthesis. You may use any necessary inorganic reagents, either labeled or not.

- (i) 1-D-ethanol
- (ii) (S)-CH₃CHDCH₂CH₃

b) Chlorobenzene reacts with concentrated aqueous NaOH under high temperature and pressure (350°C, 4500 psi), but reaction of 4-nitrochlorobenzene takes place more readily (15% NaOH, 160°C). 2,4-Dinitrochlorobenzene hydrolysed in aqueous sodium carbonate at 130°C and 2,4,6-trinitrochlorobenzene hydrolysed with water alone on warming. The products from all above reactions are the corresponding phenols.

- (i) State the type of reaction above and show the general mechanism for this reaction.
- (ii) Should 3-nitrochlorobenzene react with aqueous hydroxide faster or slower than 4-nitrochlorobenzene?
- (iii) 2,4-Dinitrochlorobenzene reacts with *N*-methylaniline to give a tertiary amine, write the structural formula of this amine.
- (iv) If 2,4-Dinitrofluorobenzene reacts with nucleophiles faster than 2,4-dinitrochlorobenzene, what information can you add to the above mechanism?

Problem 9

a) Consider the two addition reactions below.

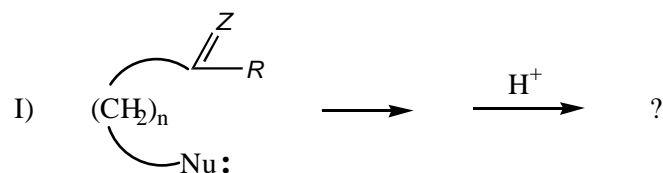

Z = O; Nu: = C, N, O, S; n = 2, 3, 4

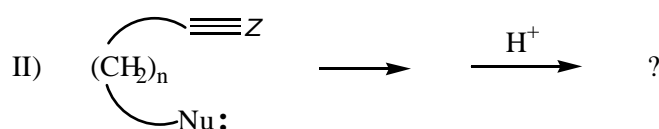

Z = N; Nu: = C, N, O, S; n = 2, 3, 4

- (i) What are the stereoisomeric products would you expect from the two reactions?
- (ii) In reaction (I), if Z = O and Nu = NH₂ what is the structure of the final product?

b) Predict the product(s) from the reaction.

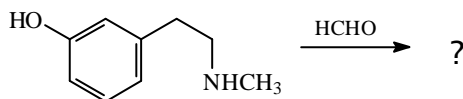

Problem 10

a) Basicity of some structural related nitrogen compounds are shown

Compound	Structure	pK _a	Compound	Structure	pK _a
pyridine		5.17	aniline		4.58
pyrrole		0.40	cyclohexylamine		10.64
pyrrolidine		11.20	<i>p</i> -aminopyridine		9.11
morpholine		8.33	<i>m</i> -aminopyridine		6.03
piperidine		11.11			

Compare and explain the differences in basicity of each of the following pairs

- (i) piperidine / pyridine
- (ii) pyridine / pyrrole
- (iii) aniline / cyclohexylamine
- (iv) *p*-aminopyridine / pyridine
- (v) morpholine / piperidine

b) The difference in physical properties of racemic *cis*-2-aminocyclohexane-1-carboxylic acid and 2-aminobenzoic acid are in the table.

	<i>cis</i> -2-aminocyclohexane-1-carboxylic acid	2-aminobenzoic acid
m.p. (°C)	240 (dec)	146-147
solubility in	water (pH 7)	insoluble
	0.1 M HCl	insoluble
	0.1 M NaOH	insoluble
	Et ₂ O	very soluble
IR absorption band (solid state, cm ⁻¹)	1610-1550	1690
pK _{a1}	3.56	2.41
pK _{a2}	10.21	4.85

- (i) Provide reasonable structures for *cis*-2-aminocyclohexane-1-carboxylic acid and 2-aminobenzoic acid at acidic, neutral and basic pH.
- (ii) If isoelectric point is defined as a pH at which the molecule have zero net charge, calculate the approximate isoelectric point of *cis*-2-aminocyclohexane-1-carboxylic acid.

Problem 11

- a) Absorption data for benzene and some derivatives is shown in the table.

Compound	Solvent	λ_{\max} (nm)	ϵ_{\max}	λ_{\max} (nm)	ϵ_{\max}	λ_{\max} (nm)	ϵ_{\max}
benzene	hexane	184	68000	204	8800	254	250
	water	180	55000	203.5	7000	254	205
phenol	water			211	6200	270	1450
phenolate ion	aq NaOH			236	9400	287	2600
aniline	water			230	8600	280	1400
	methanol			230	7000	280	1300
anilinium ion	Aq acid			203	7500	254	160

Compare and explain the differences in the absorption of each of the following pairs.

- (i) benzene and phenol
- (ii) phenol and phenolate ion
- (iii) aniline and anilinium ion
- b) Hydrolysis of compound (I), $C_{13}H_{11}N$, yielded two compounds (II), C_7H_6O , and (III) C_7H_6N . These three compounds showed the ir absorptions as follow.
- Compound (I), $C_{13}H_{11}N$: 3060, 2870, 1627, 1593, 1579, 1487, 1452, 759 and 692 cm^{-1} .
- Compound (II), C_7H_6O : 2810, 2750, 1700, 1600, 1500, 1480 and 750 cm^{-1} .
- Compound (III), C_7H_6N : 3480, 3430, 3052, 3030, 1620, 1600, 1500, 1460, 1280, 760 and 700 cm^{-1} .
- Propose the structures of compound (I)-(III).
- c) Careful hydrolysis of compound (IV), C_8H_7NO , gives compound (V), $C_8H_9NO_2$. Determine the structures of compounds (IV) and (V) from the following ir spectral data.
- Compound (IV), C_8H_7NO : 3020, 3000, 2900, 2210, 1600, 1500, 1470, 1450, 1384, 1280, 1020 and 820 cm^{-1} .
- Compound (V), $C_8H_9NO_2$: 3400, 3330, 3000, 2900, 1650, 1600, 1550, 1500, 1470, 1450, 1380, 1250, 1010 and 820 cm^{-1} .
- d) How would you expect the proton signals (chemical shift, multiplicity) in NMR spectra of isomers of alcohol C_3H_5OH .
- e) Compound (VI) reacts with 2,4-dinitrophenylhydrazine giving a solid which has the following NMR spectrum. Identify the product and structure of compound (VI).

Problem 12

Zeolite can be classified as a defect framework of porous SiO_2 where some of Si atoms are replaced by Al atoms. All metals are arranged tetrahedrally and oxygen is connected to two metal atoms. Two of the zeolite frameworks, namely “Zeolite A” and “Zeolite Y”, are shown;

The tetrahedral intersections shown here represent Si or Al atom and the framework lines represent the oxygen bridges, i.e.

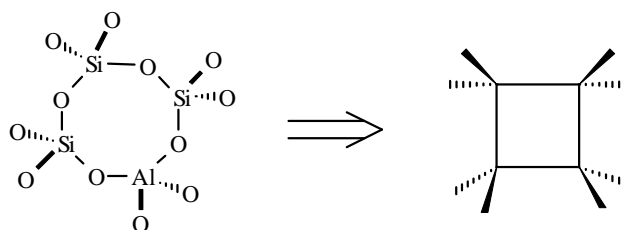

Being trivalent cation, a negative charge is generated when an aluminium atom (Al) is incorporated in the framework. Consequently, cations must be present in order to balance such negatively charge framework. These cations are called “charge balancing cations”. The interaction between these cations and the framework is highly ionic character. Therefore, these cations are exchangeable.

For example, a zeolite containing sodium (Na^+) as the exchangeable cation (Na-Zeolite) can be modified into "copper exchanged zeolite, Cu-Zeolite" by simply stirring such zeolite in dilute CuCl_2 solution at elevated temperature ($60\text{-}80^\circ\text{C}$).

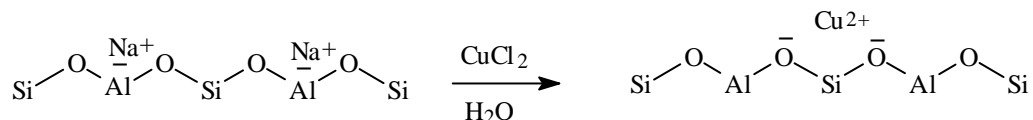

- (i) Zeolites are widely used in detergent industry for removal of calcium cations in hard water. If zeolite (I) has $\text{Si}/\text{Al} = 1$ while zeolite (II) has $\text{Si}/\text{Al} = 2$, which zeolite is more efficient for removal of calcium cations?
- (ii) Zeolites with proton as exchangeable cation, are also used as acid catalysts in petroleum refinery processes. Should zeolites with high or low Si/Al ratio possess stronger acid strength?
- (iv) At normal condition, zeolite pores are filled with water molecules. This so called "zeolitic water" can be removed from the pores by heating at $200\text{-}300^\circ\text{C}$, depending on Si/Al ratio, type of the exchangeable cations and pore size of the zeolites. The dehydrated zeolites with low Si/Al ratio, are widely used as desiccant in gas separation and purification processes. For the same Si/Al ratio, which of the zeolites containing Li, Na, or K as exchangeable cations, would absorb water most effectively.

Problem 13

In the old days of Werner's time, the studies of complexes relied entirely on the classical methods like elemental analyses, measurement of conductivities when complex dissociated to electrolytes in solution, magnetic susceptibility and magnetic moment of the complexes, identification of the existing geometrical isomers and optical isomers, etc.

a)

- (i) In the case of coordination number 6, the central metal atom can adopt three possible geometries, i.e., the flat hexagon (A1), the trigonal prism (A2), and the octahedral (A3). [Note The octahedron A3 can also be regarded as the antitrigonal prism in relation to A2].

Werner was able to arrive at the right answer by counting the number of geometrical isomers that could exist for each of the three possible geometries (A1, A2, A3), by using complexes of the formula MA_4B_2 where A and B are all monodentate ligands. You are asked to count all the possible geometrical isomers and draw their structures for each of A1, A2, A3 geometries.

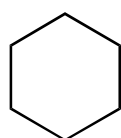

A 1

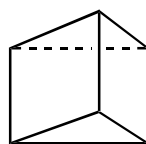

A 2

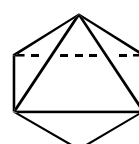

A 3

- (ii) To secure his conclusion Werner also recognized the possibility of existence of optical isomers. Let L-L be bidentate ligand and apply three (3) molecules of L-L to A1, A2, A3 geometries. Draw all the possible complexes that

would arise and identify the one(s) that would exist as optical isomer. Also draw each pair of optical isomer.

- b)
- (i) When the coordination is 4, the central metal atom can adopt either the tetrahedral or square planar geometries. Let A, B, C, D be the four monodentate ligands bond to the central metal atom, M. Compare the outcomes of the two possible geometries, i.e., tetrahedral and square planar, of MABCD with regard to geometrical and optical isomers.
 - (ii) Replace ligands A, B, C, D in (i) with two of L-L, and make the comparisons as in (i).

Problem 14

- a) The complex ion $[\text{Co}(\text{en})_3]^{3+}$, en = ethylenediamine, is diamagnetic while the ion $[\text{CoF}_6]^{3-}$ is paramagnetic. Suggest a qualitative explanation for these observations. Include diagrams showing the molecular geometry and the d-orbital energy level of these complex ions as part of your answer. Predict their magnetic properties. Which ion absorbs at longer wavelength (λ)? (Atomic number of Co is 27).
- b) A series of cobalt complexes has been synthesized and their absorption maxima measured. These are listed in the following table.

Complexes	λ_{max} , nm
1. $\text{CoCl}_3(\text{NH}_3)_6$	475
2. $\text{Co}(\text{H}_2\text{O})(\text{NO}_3)_3(\text{NH}_3)_5$	495
3. $\text{Co}(\text{CO}_3)(\text{NO}_3)(\text{NH}_3)_5$	510
4. $\text{CoF}(\text{NO}_3)_2(\text{NH}_3)_5$	515
5. $\text{CoCl}_3(\text{NH}_3)_5$	534
6. $\text{CoBr}_3(\text{NH}_3)_5$	552

- (i) Rewrite these formula according to the IUPAC guidelines and identify the complex part.
 - (ii) Give IUPAC names (in English) of the rewritten formula in (i).
 - (iii) What types of electrolytes these complexes would dissociate into when they are in solution?
 - (iv) What are the colors of these complexes?
 - (v) Rationale the difference of λ_{max} of all these complexes.
- c) Some large organic molecules with chromophore center and suitable atoms bonding to metal ions are used as reagents to detect or analyse metal ions in solution. The role of these reagents, in general, is through complexation with metal ions rendering changes of color which can easily be seen or by measuring the absorption spectra.
- 4,4'-Diazobenzene diazoaminoazobenzene (BBDAB) is one such compound which is found suitable for the analysis of Co^{2+} in solution. The absorption spectra of free BBDAB and Co-BBDAB complex are shown as follow.

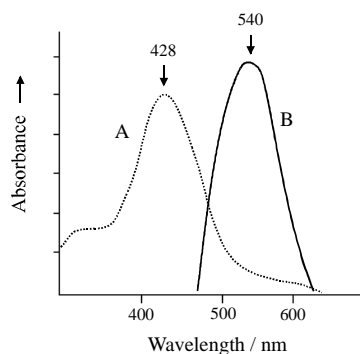

Absorption spectra of free BBDAB (A) and Co-BBDAB complex (B)

2-[2-(3,5-Dibromopyridyl)azo-5-dimethylaminobenzoic acid (3,5-diBr-PAMB) is another good reagent for cobalt analysis. The structure of this reagent is shown below.

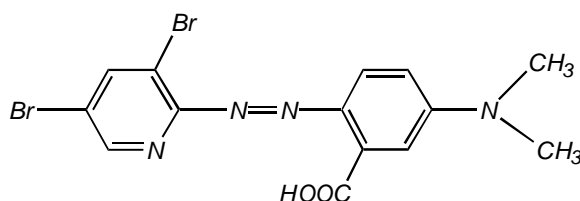

The color of visible light spectrum is given in Table.

Table Relationship of wavelengths to colors.

Wavelength, nm	Color observed
400 (violet)	Greenish yellow
450 (blue)	Yellow
490 (blue green)	Red
570 (yellow green)	Violet
580 (yellow)	Dark blue
600 (orange)	Blue
650 (red)	Blue green

- (i) According to the absorption spectrum given, what are the colors of free BBDAB and Co-BBDAB complexes?
- (ii) From the structure of 3,5-diBr-PAMB, identify the possible site(s) that would bond to the metal ion. If there are more than one possible sites, which is the most stable, thus most likely, to form? Sketch the tentative structure of the complex.
- (iii) Several other reagents can perform the same task as BBDAB and 3,5-diBr-PAMB. The examples are given in the following table along with their corresponding wavelengths at maximum absorption. What are the colors of these complexes?

Table Complexing agents with Co^{2+} ion.

Reagent	λ_{max} , nm*
1) 7-nitroso-8-hydroxyquinoline-5-sulfonic acid	530
2) 2-(2-thiazolylazo)benzoic acid	655
3) 2,2-dipyridyl-2-benzothiazolyl hydrazone	530
4) 2-(5-nitro-2-pyridineazo)-5-dimethylaminobenzoic acid	530
5) Cadion 2B	550
6) 2-(2-benzothiazolyl)azo-5-dimethylaminobenzoic acid	705

* Values for Co-reagent complexes.

Problem 15

A certain compound of Cr (chromium) was synthesized. The elemental analysis shows its composition to be : Cr 27.1 % , C 25.2 % , H 4.25 % by mass, the rest is due to oxygen.

- What is the empirical formula of this compound ?
- If the empirical formula consists of one molecule of H_2O , what is the other ligand ? What is the oxidation state of Cr ?
- The study on magnetic property shows that this compound is diamagnetic , how would you explain the magnetic property of this compound ? Sketch the possible structure of this compound.

Problem 16

From the structure given below.

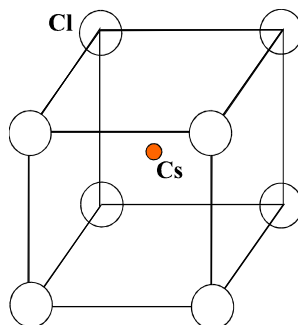

- What type of Bravais lattices, P , I , F or C (P = primitive , I = inner or body centered , C = end or side or C - centered) of the structure depicted in the Figure ?
- What is the empirical formula of this structure ?
- What is the coordination number of Cs ion ?
- In an experiment using this compound it is found that the first order reflection from the (100) plane is detected when the planes are indicated at 10.78° to the x-ray beam of wavelength 1.542 \AA . Given that the unit cell is cubic, calculate the volume.
- Calculate the density of this solid.

- (i) Write name and molecular formula of compound A.
- (ii) Write the Nernst equation for permanganate half reaction.
- (iii) How many moles of electron are required for one mole of the gaseous product?
- (iv) How many moles of electron are involved in the overall reaction?
- (v) Write the stoichiometric equation for compound A and potassium permanganate.
- (vi) What is the electronic configuration of the metal ion of compound A?
- (vii) A 0.0212 g of dried compound A is titrated with 43.30 mL of potassium permanganate solution. What is the molarity of the potassium permanganate solution?
- (viii) Does acidified potassium permanganate have a thermodynamic tendency to oxidize metal M to M^+ , if $E^\circ(M^+, M) = +1.69$ V?
- (ix) Calculate the biological standard potential of the half reaction in (viii).

Problem 19

a) A weak organic acid HA is distributed between aqueous solution and carbon tetrachloride.

- (i) Derive the distribution ratio ($D_{\text{CCl}_4/\text{H}_2\text{O}}$), in term of acid dissociation constant (K_a), and distribution coefficient (K_d). Given that

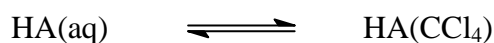

- (ii) Extraction experiments at various pH give the following results:

pH	Distribution ratio ($D_{\text{CCl}_4/\text{H}_2\text{O}}$)
1	5.200
3	5.180
4	5.190
6	2.605
7	0.470
8.0	0.052
8.5	0.016

Estimate the equilibrium constants K_a and K_d .

b) In a chromatographic separation, using a 30.0 cm column, substances A and B have retention times (t_R) of 16.40 and 17.63 min, respectively. Unretained species passes through the column in 1.30 min. The peak widths at the base line for A (W_A) and B (W_B) are 1.11 and 1.21 min, respectively. Calculate:

- (i) the resolution (R_s)
- (ii) the average number of theoretical plate of the column, N
- (iii) the plate height, H

- (iv) the length of column (L) required to achieve a resolution of 1.5.

Problem 20

a) The mass spectrum of dichloromethane, CH_2Cl_2 , has characteristic peaks at m/z 49 (base peak), 51, 84 (molecular ion), 86 and 88. Predict the relative intensities of these peaks.

- (i) m/z 49 and 51
 (ii) m/z 84, 86 and 88

b) Calculate the ratios of the isotopic peaks expected in the mass spectrum of a compound containing three bromine atoms.

Table: Selected Elements and Their Relative Abundances

Element	Mass No.	Relative Abundance (%)
H	1	99.985
	2	0.015
C	12	98.889
	13	1.111
N	14	99.634
	15	0.366
O	16	99.763
	17	0.037
	18	0.200
Cl	35	75.77
	37	24.23
Br	79	50.69
	81	49.31

Problem 21

Solutions X, Y obey Beer's Law over a wide concentration range. Spectral data for these species in a 1.00-cm cell are as follow:

λ (nm)	Absorbance	
	X, 8.00×10^{-5} M	Y, 2.00×10^{-4} M
400	0.077	0.555
440	0.096	0.600
480	0.106	0.564
520	0.113	0.433
560	0.126	0.254
600	0.264	0.100
660	0.373	0.030
700	0.346	0.063

- (i) Calculate molar absorptivities of X and Y at 440 and 660 nm.
 (ii) Calculate the absorbances for a solution that is 3.00×10^{-5} M in X and

- 5.00x10⁻⁴ M in Y at 520 and 600 nm.
- (iii) A solution containing X and Y shows absorbances of 0.400 and 0.500 at 440 and 660 nm respectively. Calculate the concentrations of X and Y in the solution. Assume no reaction occurs between X and Y.

Problem 22 : Experiment

Iodometry; Determination of Cu²⁺ in solution

In this experiment you will carry out a volumetric determination of Cu²⁺ by reaction with iodine ion. The basis of this iodometric determination is the observation that Cu²⁺ ion is quantitatively reduced to insoluble copper (I) iodide by excess iodide ion:

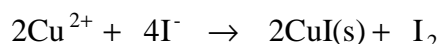

Molecular iodine is very slightly soluble in water, but its solubility is increased considerably by combination with the ion to form the brown-colored triiodide ion:



The triiodide ion is then titrated with standard sodium thiosulfate solution (Na₂S₂O₃), trivial name: photographer's "hypo"). The thiosulfate ion is oxidized to the tetrathionate ion:

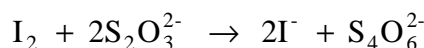
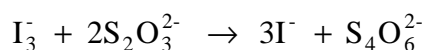

During the titration the intensity of the brown color diminishes. The addition of starch solution to the almost colorless solution produces the dark blue color of a complex formed from starch and iodine. The end point is indicated by the disappearance of the blue color. The blue color may reappear upon standing. However, the first disappearance of the blue color indicates the end point.

Because of the tendency of the hydrate Na₂S₂O₃ (H₂O)₅ to effloresce and of the anhydrous salt Na₂S₂O₃ to combine with water vapor under ordinary conditions,



sodiumthiosulfate is not acceptable as a primary standard. Hence, for precise work, it is necessary to standardize thiosulfate solution, usually with potassium iodate, KIO₃.

Procedure

Reagents

E q u i p m e n t

0.01000 M Na ₂ S ₂ O ₃	25 - mL burette
5.0 M acetic acid	3 x 250-mL erlenmeyer flask
2.0 M KI	20 - mL pipette
starch solution	10 - mL graduate cylinder

Obtain an unknown solution containing Cu²⁺ ion. Pipet 20.00 mL of the solution into a 250-mL Erlenmeyer flask. Add 10 mL of 5.0 M acetic acid and 10 mL of 2.0 M KI. Titrate with

the 0.10 M thiosulfate solution until iodine color becomes pale yellow. Add 2-3 drops of starch solution, and titrate until the blue color disappears. Repeat the titration 3 times.

Calculate the molarity of Cu^{2+} ion in the unknown solution. Assume that the unknown is a solution of copper (II) nitrate, calculate the weight of copper (II) nitrate per liter of solution.

Problem 23: Experiment

Chromatography and Complexometry

Concentration of copper (II) followed by EDTA titration

Conventional anion and cation exchange resins appear to be limited use for concentrating trace metals from saline solutions such as seawater. The introduction of chelating resins, particularly those based on iminodiacetic acid, makes it possible to concentrate trace metals from brine solutions and separate them from the major components of the solution. With a suitable chelating resin (e.g. Chelex-100) and eluent of appropriate strength, copper (II) is selectively retained by the resin (Hres) and can be recovered subsequently for determination. The eluate containing Cu(II) can be determined by direct titration with EDTA (H_2Y^{2-}) using Alizarin complexone as indicator.

Concentration:

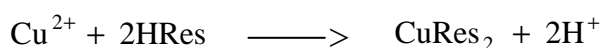

Elution:

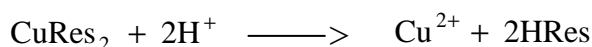

Titration:

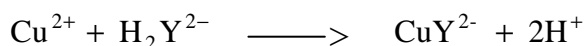

End point:

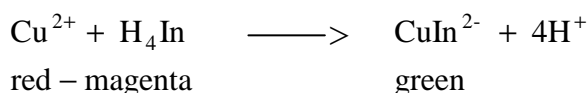

Solutions and Chemicals:

2 M nitric acid

Chelex-100 resin (>100 mesh) or equivalent chelating resins
0.5% Alizarin complexone (in dilute ammonia acetate solution) Sodium acetate/acetic acid in buffer pH 4.3 Standard 0.01 M EDTA solution (Calculate the exact molarity from your own preparation). Brine sample solution-to be supplied by the instructor in charge.

Procedure:

- 1) **Preparation of the chelating resin column:**
Prepare the Chelex-100 resin by digesting it with an excess (~ 2-3 bed-volumes) of 2 M nitric acid at room temperature. Repeat this process twice and then transfer sufficient resin to fill a 1.0 cm diameter column to a height of 10 cm. Wash the resin column with several bed-volumes of deionised water.
- 2) **Concentration of copper (II) ion from the brine sample solution:**
Allow the whole of the sample solution (500 mL) to flow through the resin column at a rate not exceeding 10 mL/min. Use a stopwatch to ensure the appropriate flowrate. Wash the column with 100 mL deionised water and reject the washings. Elute the copper (II) ions with 25 mL of 2 M nitric acid. Add deionised water to the mark of a 50-mL volumetric flask.
- 2) **Titration of copper:**
From the 50-mL volumetric flask containing all the eluted copper (II) ions, use a 10-mL pipette to take 3 aliquots of 10 mL each into three conical flasks. To each flask, add 100 mL deionised water before treating it with 5-8 drops of Alizarin complexone indicator to obtain a red magenta color upon addition of the pH 4.3 buffer solution. Titrate the solution in each flask with the standard solution of EDTA to the green end point.

Calculation:

From the millimoles EDTA taken, calculate and report the following:

- (i) Millimols of Cu (II) in each 10 mL aliquot titrated.
- (ii) Concentration of Cu (II) in the original brine sample solution in $\mu\text{g/L}$

Problem 24**Preparation and Separation of *o*-Nitrophenol and *p*-Nitrophenol**

Electrophilic substitution in the highly activated phenol ring occurs under very mild conditions, and mononitration must be carried out with dilute aqueous nitric acid. The usual nitric acid/sulfuric acid mixture gives a complex mixture of polynitro compounds and oxidation products.

Separation of *o*- and *p*-nitrophenol can be accomplished by taking advantage of the strong intramolecular hydrogen bonding in the *ortho* isomer (I). In the *para* isomer (II), the hydrogen bonding is intermolecular, and these attractive force between the molecules lead to a lower vapor pressure. On steam distillation of the mixture, the *ortho* isomer is obtained in pure form in the distillate. The *para* isomer can then be isolated from the nonvolatile residue.

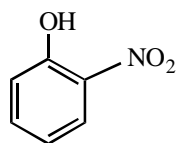
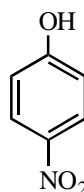
**I****II**

Procedure

In a 25-mL Erlenmeyer flask, add 1 mL of concentrated nitric acid to 4 mL of water. Weight out 0.9 g of “liquid phenol” (approximately 90% phenol in water; density 1.06 g/mL) in a 5-mL beaker (**CAUTION:** phenol is corrosive; avoid contact with skin). With a disposable pipet, add phenol to the nitric acid and cool as necessary by swirling the flask in a pan of cold water. After all of the phenol has been added (rinse the beaker with ~1 mL of cold water), swirl the flask intermittently for 5 to 10 minutes while the contents cool to room temperature. Meanwhile assemble the apparatus for a steam distillation.

Transfer the reaction mixture to a 15-mL screwcapped centrifuge tube and use a Pasteur pipet transfer the oily organic layer to a clean 50-mL round-bottom flask. (If the mixture is so dark that separate layers are not evident, add 2 mL of water). Add 20 mL of water, and then carry out a steam distillation until no further *o*-nitrophenol appears in the distillate. Collect the *o*-nitrophenol by filtration, allow it to air dry, then determine yield and melting point.

For the isolation of the *p*-nitrophenol, adjust the total volume of the distillation residue to approximately 20 mL by adding more water or removing water by distillation. Decant the hot mixture through a coarse fluted filter or cotton plug, and add approximately 0.2 g charcoal and 2 drops of concentrated, hydrochloric acid to the hot filtrate, heat again to boiling, and filter through fluted filter paper to remove the charcoal. Chill a 50-mL Erlenmeyer flask in ice, and pour a small portion of the hot *p*-nitrophenol solution into it to promote rapid crystallization and prevent the separation of the product as an oil. Add the remainder of the solution in small portions so that each is quickly chilled. Collect the crystals by vacuum filtration air dry, and determine the yield and melting point.

Submit both isomers to your instructor in appropriately labeled containers.

Problem 25

Two-Component Mixture Separation by Solvent Extraction

This experiment illustrates an example of the solvent extraction technique as it is used in the organic laboratory to separate organic acids and bases. The solubility characteristics of these important organic compounds in water are dependent on the pH of the solution. The extraction procedure employed for the separation of a mixture of an acid, a base, or a neutral substance takes advantage of this fact.

a) Separation of the Acid-Base mixture

The components of the mixture to be separated in this experiment are benzoic acid and 4-chloroaniline (a base).

Procedure

In a stoppered or capped 15-mL centrifuge tube containing 4 mL of dichloromethane are added 50 mg (0.41 mmol) of benzoic acid and 50 mg (0.39 mmol) of 4-chloroaniline. Dissolution of the solids is accomplished by stirring with a glass rod or mixing on a Vortex mixer.

HOOD! The dichloromethane is measured using a 10-mL graduated cylinder. It is dispensed in the hood.

Separation of the Basic Component

Using a calibrated Pasteur pipet, 2 mL of 3 M hydrochloric acid are added to the centrifuge tube while cooled in an ice bath, and the resulting two-phase system mixed thoroughly for several minutes (a Vortex mixer is excellent for this purpose). After the layers have separated, the aqueous layer is removed, using a Pasteur filter pipet, and transferred to a **labeled**, 10-mL Erlenmeyer flask.

Note. A small amount of crystalline material may form at the interface between the layers. The second extraction dissolves this material.

This step is now repeated with an additional 2 mL of the 3 M acid solution and the aqueous layer again transferred to the same Erlenmeyer flask. This flask is now stoppered (capped) and set aside.

Isolation of the 4-chloroaniline

To the acidic aqueous solution, separated and set aside, add 6 M NaOH dropwise until the solution is distinctly alkaline to litmus paper. Cool the flask in an ice bath for about 10-15 minutes. Collect the solid precipitate by reduced-pressure filtration using a Hirsch funnel. Wash the precipitate with two 1-mL portions of distilled water. Dry the material on a clay plate, on filter paper, or in a vacuum drying oven. Weigh your product and calculate the percentage recovery. Obtain a melting point of the dried material and compare your result with the literature value.

Separation of the Acidic Component

To the remaining dichloromethane solution now add 2 mL of 3 M NaOH. The system is mixed as before and the aqueous layer is separated and transferred to a labeled, 10-mL Erlenmeyer flask.

This step is repeated and the aqueous layer again removed and transferred to the same Erlenmeyer flask. This flask is stoppered and set aside.

Isolation of the Benzoic Acid

To the aqueous alkaline solution, separated and set aside, add 6 M HCl dropwise until the solution is distinctly acidic to litmus paper. Cool the flask in an ice bath for about 10 minutes. Collect the precipitated benzoic acid by reduced pressure filtration using a Hirsch funnel. Wash the precipitate with two 1-mL portions of distilled water. Dry the product using one of the techniques described earlier for the 4-chloroaniline. Weigh the benzoic acid and calculate your percentage recovery. Obtain the melting point of the dried material and compare your result with the literature value. The qualitative test for organic carboxylic acids may also be performed.

b) Separation of the Acid-Neutral mixture

The components of the mixture to be separated in this experiment are benzoic acid and 9-fluorenone.

Procedure

In a stoppered or capped 15-mL centrifuge tube containing 4 mL of dichloromethane are added 50 mg (0.41 mmol) of benzoic acid and 50 mg (0.27 mmol) of 9-fluorenone. Dissolution of the solids is accomplished by stirring with a glass rod or mixing on a Vortex mixer.

Separation of the Acidic Component

Using a calibrated Pasteur pipet, 2 mL of 3 M NaOH are added to the centrifuge tube while cooled in an ice bath, and the resulting two-phase system mixed thoroughly for several minutes (a Vortex mixer is excellent for this purpose). After the layers have separated, the aqueous layer is removed, using a Pasteur filter pipet, and transferred to a **labeled**, 10-mL Erlenmeyer flask.

This step is now repeated with an additional 2 mL of the 3 M NaOH and the aqueous layer again transferred to the same Erlenmeyer flask. This flask is now stoppered (capped) and set aside.

Isolation of the Benzoic Acid

To the aqueous alkaline solution, separated and set aside, add 6 M HCl dropwise until the solution is distinctly acidic to litmus paper. Cool the flask in an ice bath for about 10 minutes. Collect the precipitated benzoic acid by reduced pressure filtration using a Hirsch funnel. Wash the precipitate with two 1-mL portions of distilled water. Dry the product using one of the techniques described earlier for the 4-chloroaniline. Weigh the benzoic acid and calculate your percentage recovery. Obtain the melting point of the dried material and compare your result with the literature value. The qualitative test for organic carboxylic acids may also be performed.

Separation of the Neutral Component

After washing with two 1-mL portions of distilled water, to the remaining wet, dichloromethane solution in the centrifuge tube add about 250 mg of anhydrous sodium sulfate. Set this mixture aside while working up the other extraction solution. This will allow sufficient time for the solution to dry. If the drying agent clumps, add additional sodium sulfate.

Isolation of the 9-Fluorenone

Transfer the dried dichloromethane solution by use of a Pasteur filter pipet to a tared 10-mL Erlenmeyer flask containing a boiling stone. Rinse the drying agent with an additional 1 mL of dichloromethane and also transfer this rinse to the same Erlenmeyer flask.

HOOD! Concentrate the solution on a water bath in the **hood**. Obtain the weight of the isolated 9-fluorenone and calculate the percentage recovery. Obtain a melting point of the material and compare your result with the literature value.

Problem 26

Organic Qualitative Analysis

You are given five bottles containing five different organic compounds. Identify the class (alkene, alcohol, aldehyde, ketone, carboxylic acid, amine or phenol) of each compound using the tests listed below. You are not required to performed each test on each bottle.

Many of these compounds have distinctive odors. To prevent the lab from becoming too odorous, you must keep each bottle tightly capped and dispose of the waste material in the bottle labeled “ **ORGANIC WASTE** ” at your station.

Chemicals Available

2,4-dinitrophenylhydrazine	semicarbazide hydrochloride
aqueous ceric ammonium nitrate	Lucas reagent
aqueous chromic sulfuric acid	<i>p</i> -toluenesulfonyl chloride
2% Br ₂ /CH ₂ Cl ₂	3,5-dinitrobenzoyl chloride
S-(<i>p</i> -bromobenzyl)thiuronium bromide	ethanol
aqueous 1% FeCl ₃	5% NaHCO ₃
5% and 10% NaOH	5% and 10% HCl
5% and 10% NaOH	2% Na ₂ CO ₃
anhydrous CaCl ₂	

Standard Reagent Tests and Procedures

a) Ceric Ammonium Nitrate Test:

Place 5 drops of the ceric ammonium nitrate reagent into a small test tube. Add 1-2 drops of the compound to be tested. Observe and record any color change. Dispose of the resulting solution in a waste bottle.

- (i) If the alcohol is water-insoluble, 3-5 drops of dioxane may be added, but run a blank to make sure the dioxane is pure. Efficient stirring gives positive results with most alcohols.
- (iii) Phenols, if present, give a brown color or precipitate.

b) Bromine Test:

Place two drops of the compound (15 mg if a solid) to be tested into a small test tube. Add two drops of the bromine test solution and gently shake the test tube. Note any changes which occur within one minute. Dispose of the resulting solution in a waste bottle.

CAUTION: *Bromine is highly toxic and can cause burns.*

c) Ferric Chloride Test:

Place two drops of the compound to be tested into a small test tube. Add two drops of the ferric chloride test solution and gently shake the test tube. Note any color changes. Dispose of the resulting solution in a waste bottle.

d) Chromic Anhydride Test: The Jones Oxidation

Place five drops of the liquid compound (10 mg if a solid) to be tested into a small test tube. Add one drop of the chromic acid test solution. Observe and record any color change within two seconds. Dispose of the resulting solution in a waste bottle.

e) **2,4-Dinitrophenylhydrazine Test:**

Place 7-8 drops of 2,4-Dinitrophenylhydrazine reagent into a small test tube. Add 1 drop of liquid compound. If the unknown is solid, add 1 drop of a solution prepared by dissolving 5 mg of the material in 5 drops of ethanol. The mixture is stirred with a thin glass rod. Observe and record any change within 2-3 seconds.

f) **The Lucas Test:**

In a small test tube, place 2 drops of the compound (10 mg if a solid) to be tested followed by 10 drops of Lucas reagent. Shake or stir the mixture with a thin glass rod and allow the solution to stand. Observe the results.

g) **The Hinsberg Test:**

In a 1.0-mL conical vial containing a boiling stone and equipped with an air condenser place 0.5 mL of 10% aqueous sodium hydroxide solution, 1 drop of the sample (10 mg if a solid), followed by 30 mg of *p*-toluenesulfonyl chloride [**Hood!**]. The mixture is heated to reflux for 2-3 minutes on a sand bath and cooled in an ice bath. Test the alkalinity of the solution using litmus paper. If it is not alkaline, add additional 10% aqueous NaOH dropwise.

Using a Pasteur filter pipet, separate the solution from any solid that may be present. Transfer the solution to a clean 1.0-mL conical vial [**save**].

Note: If an oily upper layer is obtained at this stage, remove the lower alkaline phase [**save**] using a Pasteur filter pipet. To the remaining oil add 0.5 mL of cold water and stir vigorously to obtain a solid material.

If a solid is obtained it may be (1) the sulfonamide of a secondary amine, (2) recovered tertiary amine if the original amine was a solid, or (3) the insoluble salt of a primary sulfonamide derivative (if the original amine had more than six carbon atoms).

- (i) If the solid is a tertiary amine, it is soluble in aqueous 10% HCl.
- (ii) If the solid is a secondary sulfonamide, it is insoluble in aqueous 10% NaOH
- (iii) If no solid is present, acidify the alkaline solution by adding 10% aqueous HCl. If the unknown is a primary amine, the sulfonamide will precipitate.

Preparation of Derivatives

a) **2,4-Dinitrophenylhydrazone**

Place 7-8 drops of 2,4-Dinitrophenylhydrazine reagent into a small test tube. Add 1 drop of liquid compound. If the unknown is solid, add 1 drop of a solution prepared by dissolving 5 mg of the material in 5 drops of ethanol. The mixture is stirred with a thin glass rod. Collect a red to yellow precipitate by vacuum filtration using a Hirsch funnel and recrystallize from 95% ethanol. Collect the crystals by vacuum filtration using a Hirsch funnel and wash the crystals with 0.2 mL of cold water. Dry the crystals on a watch glass. Determine the melting point.

b) Semicarbazone

In a 1.0 mL conical vial, place 12 mg of semicarbazide hydrochloride, 20 mg of sodium acetate, 10 drops of water, and 12 mg of the unknown carbonyl compound. Cap the vial, shake vigorously, vent and allow the vial to stand at room temperature until crystallization is complete. Cool the vial in an ice bath if necessary. Collect the crystals by vacuum filtration using a Hirsch funnel and wash the filter cake with 0.2 mL of cold water. Dry the crystals on a porous clay plate or on filter paper. Determine the melting point.

c) 3,5-Dinitrobenzoate

In a 1.0 mL-conical vial containing a boiling stone and equipped with an air condenser protected by a calcium chloride drying tube are placed 25 mg of 3,5-dinitrobenzoyl chloride and 2 drops of the unknown alcohol or phenol. The mixture is then heated to ~ 10°C below the boiling point of the unknown alcohol or phenol (but not over 100°C) on a sand bath for a period of 5 minutes. Water (0.3 mL) is added and the vial placed in an ice bath to cool. The solid ester is collected by vacuum filtration using a Hirsch funnel and the filter cake washed with three 0.5 mL-portions of 2% aqueous sodium carbonate solution followed by 0.5 mL of water. The solid product is recrystallized from an ethanol-water mixture using a Craig tube. Dissolve the material in ~0.5 mL of ethanol. Add water (dropwise) to the cloud point, cool in an ice bath, and collect the crystals in the usual manner. After drying the product on a porous clay plate or on filter paper determine the melting point.

d) *p*-Bromobenzylthiuronium Salt

About 30 mg of the acid is added to 0.3 mL of water, a drop of phenolphthalein indicator solution is added, and the solution is neutralized by the dropwise addition of 5% sodium hydroxide solution. An excess of alkali must be avoided. If too much is used, dilute hydrochloric acid is added until the solution is just a pale pink. To this aqueous solution of the sodium salt is added a hot solution of 1 g of the *S*-(*p*-bromobenzyl)thiuronium bromide in 1 mL of 95% ethanol. The mixture is cooled, and the salt is collected on a filter.

This thiuronium salts of organic acids separate in a stage of high purity and usually do not require recrystallization. If necessary they may be recrystallized from a small amount of dioxane.

Worked solutions to the problems

Problem 1

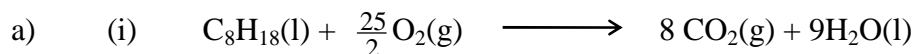

The heat capacity of the calorimeter and its content is

$$C_s = 48 + (750 \times 4.184) = 3186 \text{ J K}^{-1}$$

The amount of heat released at constant volume is

$$q_v = C_s \Delta T = (3186 \text{ J K}^{-1})(8.220 \text{ K}) = 2.619 \times 10^4 \text{ J} = 26.19 \text{ kJ}$$

Hence, we obtain:

$$\Delta U^\circ = -q_v = -26.19 \text{ kJ}$$

(ii) For the combustion of 1 mole of isooctane:

$$\Delta U^\circ = - \frac{(114.23 \text{ g mol}^{-1})(26.19 \text{ kJ})}{0.542 \text{ g}} = -5520 \text{ kJ mol}^{-1}$$

(iii) The enthalpy change (ΔH°) is related to ΔU° as follows:

$$\Delta H^\circ = \Delta U^\circ + \Delta n_{\text{gas}}(\text{RT})$$

$$\text{From the reaction : } \Delta n_{\text{gas}} = 8 - \frac{25}{2} = -\frac{9}{2} \text{ mol}$$

$$\begin{aligned} \text{Thus, } \Delta n_{\text{gas}}(\text{RT}) &= \left(-\frac{9}{2}\right) (8.314 \text{ J mol}^{-1} \text{ K}^{-1})(298.15 \text{ K}) \\ &= -11.15 \times 10^3 \text{ J} \end{aligned}$$

As ΔU° is given in kJ, we obtain

$$\Delta H^\circ = \Delta U^\circ - 11.15 = -5520 - 11.15 = -5531 \text{ kJ mol}^{-1}$$

(iv) Since $\Delta H^\circ = 8\Delta H_f^\circ, \text{CO}_2(\text{g}) + 9\Delta H_f^\circ, \text{H}_2\text{O}(\text{l}) - \Delta H_f^\circ, \text{C}_8\text{H}_{18}(\text{l})$

Therefore

$$\begin{aligned} \Delta H_f^\circ, \text{C}_8\text{H}_{18}(\text{l}) &= 8(-393.51) + 9(-285.83) - (-5531) \\ &= -190 \text{ kJ mol}^{-1} \end{aligned}$$

b) (i) From $\Delta G^\circ = -RT \ln K$, then

$$\ln K = -\frac{\Delta G^\circ}{RT} = \frac{-\Delta H^\circ}{RT} + \frac{\Delta S^\circ}{R}$$

If the lower temperature, 298.15 K, is written as T_1 ,

$$\ln K_1 = \frac{-\Delta H^\circ}{RT_1} + \frac{\Delta S^\circ}{R}$$

Similarly, for the higher temperature 313.15 K

$$\ln K_2 = \frac{-\Delta H^\circ}{RT_2} + \frac{\Delta S^\circ}{R}$$

$$\text{Thus } \ln \frac{K_2}{K_1} = \frac{\Delta H^\circ}{R} \left(\frac{T_2 - T_1}{T_1 T_2} \right)$$

$$\ln \frac{3.45 \times 10^3}{1.80 \times 10^3} = \frac{\Delta H^\circ \text{ J mol}^{-1}}{8.314} \cdot \frac{15.00 \text{ K}}{(298.15 \text{ K})(313.15 \text{ K})}$$

$$\Delta H^\circ = 33.67 \text{ kJ mol}^{-1}$$

For ΔS°

$$\ln 3.45 \times 10^3 = 8.146 = \frac{-33670 \text{ J mol}^{-1}}{(8.314 \text{ J mol}^{-1} \text{ K}^{-1})(313.15 \text{ K})} + \frac{\Delta S^\circ \text{ J mol}^{-1}}{8.314 \text{ J K}^{-1} \text{ mol}^{-1}}$$

so that $\Delta S^\circ = 175.2 \text{ J K}^{-1} \text{ mol}^{-1}$

(ii) From the given equation, we obtain

$$K_p = \frac{P_{AB}}{P_A \cdot P_B}$$

From $PV = nRT$, then

$$K_p = \frac{[AB](RT)}{[A](RT)[B](RT)} = \frac{K_c}{RT}$$

At 298.15 K

$$K_p = \frac{(1.80 \times 10^3 \text{ L mol}^{-1})}{(8.314 \text{ atm L K}^{-1} \text{ mol}^{-1})(298.15 \text{ K})} = 0.726 \text{ atm}^{-1}$$

From $P_1 = X_1P$, then

$$K_p = \frac{X_{AB}}{X_A \cdot X_B} \cdot P^{-1} = K_x \cdot P^{-1}$$

$$K_x = K_p \cdot P = (0.736 \text{ atm}^{-1})(1 \text{ atm}) = 0.726$$

c) From $\ln \frac{K_2}{K_1} = \frac{\Delta H^\circ}{R} \left(\frac{T_2 - T_1}{T_1 T_2} \right)$

Choose any two values of K at two different temperature, i.e. at 15.2°C (288.4 K) and 34.9°C (308.2 K).

$$\ln \frac{530}{840} = \frac{\Delta H^\circ}{8.314} \left(\frac{308.2 - 288.4}{288.4 \times 308.2} \right)$$

$$\Delta H^\circ = -1.72 \times 10^4 \text{ J} = -17.2 \text{ kJ}$$

OR

$$\text{From } \ln K = \frac{\Delta S^\circ}{R} - \frac{\Delta H^\circ}{R} \cdot \frac{1}{T}$$

ΔH° and ΔS° are assumed to be constant. A plot of $\ln K$ against $1/T$ should be a straight line of slope equal to $-\Delta H^\circ/R$

T(Kelvin)	:	288.4	298.2	308.1
K	:	840	690	530
$10^3/T$:	3.47	3.36	3.25
$\ln K$:	6.73	6.54	6.28

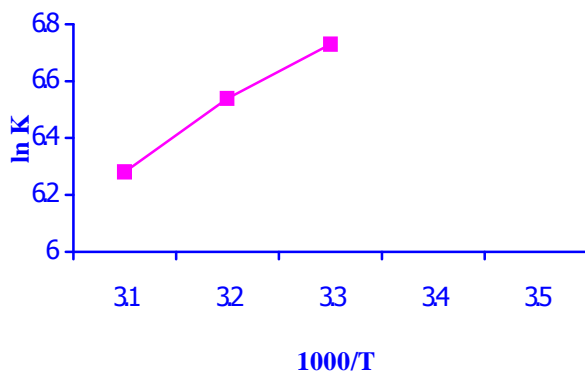

$$\text{Slope} = -\frac{\Delta H^\circ}{8.314} = 2.06 \times 10^3$$

$$\Delta H^\circ = -1.71 \times 10^4 \text{ J} = -17.1 \text{ kJ}$$

Problem 2

- a) (i) By calculation from the Raoult's law : $P_i = X_i P_i^\circ$, hence

X_C	:	0.20	0.40	0.60	0.80
$P_C = X_C P_C^\circ$ (torr)	:	59	117	176	234
P_C (measured)(torr)	:	35	82	142	219
$(P_C^\circ = 293 \text{ torr})$					

X_A	:	0.80	0.60	0.40	0.20
$P_A = X_A P_A^\circ$ (torr)	:	277	208	139	69
P_A (measured)(torr)	:	270	185	102	37
$(P_A^\circ = 347 \text{ torr})$					

It can be seen that the calculated vapor pressures of both acetone and chloroform are higher than the measured values at all proportions. Thus, the solutions deviated from ideal solution.

It can be shown, however, by plotting the pressure-composition diagram as follows:

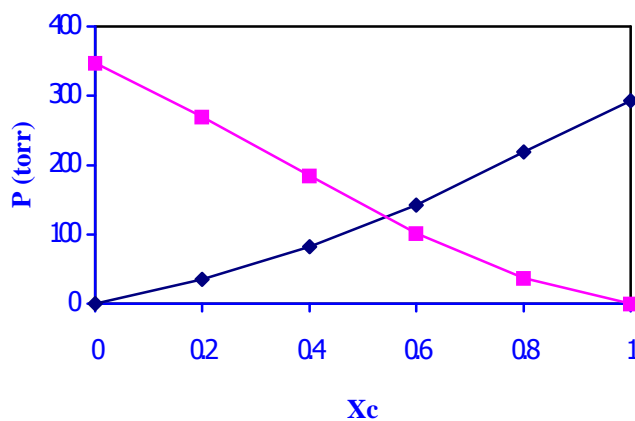

- (ii) The solutions exhibit negative deviation from ideal behavior.

- (iii) From the data given, we can then calculate the activity of chloroform and acetone:

X_C	:	0.20	0.40	0.60	0.80
$a_C = P_C / P_C^\circ$:	0.12	0.28	0.48	0.75
X_A	:	0.80	0.60	0.40	0.20
$a_A = P_A / P_A^\circ$:	0.78	0.53	0.29	0.11

The activities of both chloroform and acetone are less than the mole fractions indicating negative deviation from ideal behavior.

- b) (i) From the Gibbs-Helmholtz equation,

$$\frac{d \ln X_1}{dT} = \frac{\Delta H_{\text{fus}}^\circ}{RT^2} \quad (1)$$

Where X_1 is the mole fraction of the liquid solvent and $\Delta H_{\text{fus}}^\circ$, the heat of fusion of pure solvent. If $\Delta H_{\text{fus}}^\circ$ is independent of T over a moderate range of

temperature, we may integrate Eq.(1) from T_f° , the freezing point of pure solvent at $X_1 = 1$, to T , the temperature at which solid solvent is in equilibrium with liquid solvent of mole fraction X_1 . The result is

$$\ln X_1 = \frac{\Delta H_{\text{fus}}^\circ}{R} \left(\frac{1}{T_f^\circ} - \frac{1}{T} \right) \quad (2)$$

By expressing X_1 , in terms of X_2 , the mole fraction of the solute:

$$\ln (1-X_2) = \frac{\Delta H_{\text{fus}}^\circ}{R} \left(\frac{T - T_f^\circ}{T \cdot T_f^\circ} \right) \quad (3)$$

If X_2 is small (corresponding to a solution), then

$$\ln (1-X_2) \sim -X_2$$

The freezing point depression is $T_f^\circ - T = \Delta T_f$. Since ΔT_f is small in comparison to T_f° , we may set the product $TT_f^\circ \sim T_f^{\circ 2}$. These changes convert Eq. (3) to

$$X_2 = \frac{\Delta H_{\text{fus}}^\circ}{R} \cdot \frac{\Delta T_f}{T_f^{\circ 2}} \quad (4)$$

In dilute solution, $X_2 = n_2 / (n_1 + n_2) \sim n_2 / n_1$.

The molality m_2 is related to the amount of n_2 of solute by $m_2 = \frac{n_2}{w_1} \times 1000$

where w_1 is the mass in grams of solvent.

For the solvent $n_1 = w_1 / M_1$, where M_1 is its molar mass.

Then $X_2 = m_2 M_1 / 1000$.

Rearrangement of Eq. (4) and substitution for X_2 yields

$$\Delta T_f \sim \frac{M_1 R T_f^{\circ 2}}{\Delta H_f \cdot 1000} \cdot m_2 \quad (5)$$

The freezing point depression or cryoscopic constant K_f defined as

$$K_f = \frac{M_1 R T_f^2}{\Delta H_f \cdot 1000} \quad (6)$$

Therefore,

$$\begin{aligned} K_f &= \frac{(147.01 \text{ g mol}^{-1})(8.314 \text{ J K}^{-1} \text{ mol}^{-1})(326.28 \text{ K})^2}{(17880 \text{ J mol}^{-1})(1000 \text{ g kg}^{-1})} \\ &= 7.26 \text{ K kg mol}^{-1} \end{aligned}$$

(ii) $\Delta T_f = 326.28 - 323.78 = 2.50 \text{ K}$

With the definition of K_f , Eq. (6) may be expressed as

$$\Delta T_f = K_f \cdot m_2 \quad (7)$$

$$\text{Since } m_2 = \frac{n_2}{w_1} \cdot 1000 = \frac{w_2 \cdot 1000}{w_1 \cdot M_2} \quad (8)$$

where M_2 is the molar mass of solute.

After rearrangement, we have

$$\begin{aligned} M_2 &= \frac{K_f \cdot w_2 \cdot 1000}{\Delta T_f \cdot w_1} \quad (9) \\ &= \frac{(7.26 \text{ K kg mol}^{-1})(1.50 \text{ g})(1000 \text{ g kg}^{-1})}{(2.50 \text{ K})(30.0 \text{ g})} \\ &= 145.6 \text{ g mol}^{-1} \end{aligned}$$

(iii) Using Eq. (2) we obtain

$$\ln X = \frac{17880}{8.314} \left(\frac{1}{326.28} - \frac{1}{298.15} \right) = -0.622$$

$$X = 0.537$$

The mole-fraction solubility of *p*-dichlorobenzene at 298.15 K in an ideal solution is, therefore, equal to 0.537.

Problem 3

a) (i) Reaction and total kinetic energy

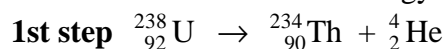

$$\begin{aligned} Q &= K_d + K_\alpha = [m({}^{238}\text{U}) - m({}^{234}\text{Th}) - m({}^4\text{He})]c^2 \\ &= [238.05079 \text{ u} - 234.04360 \text{ u} - 4.00260 \text{ u}]931.5 \text{ MeV u}^{-1} \\ &= (4.59 \times 10^{-3} \text{ u})(931.5 \text{ MeV u}^{-1}) = 4.28 \text{ MeV} \end{aligned}$$

K_d and K_α are KE of daughter and α -particle.

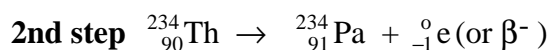

$$\begin{aligned} Q &= K_d + K_\beta = [m({}^{234}\text{Th}) - m({}^{234}\text{Pa})]c^2 \\ &= [234.04360 \text{ u} - 234.04332 \text{ u}] 931.5 \text{ MeV u}^{-1} \\ &= (2.8 \times 10^{-4} \text{ u})(931.5 \text{ MeV u}^{-1}) = 0.26 \text{ MeV} \end{aligned}$$

(ii) At equilibrium (secular) $N_1 \lambda_1 = N_2 \lambda_2 = A$ (where A is activity)

$$\text{For } ^{226}\text{Ra}, \lambda_1 = \frac{0.693}{(1620)(365)} = 1.17 \times 10^{-6} \text{ d}^{-1}$$

$$\text{For } ^{222}\text{Rn}, \lambda_2 = \frac{0.693}{3.8} = 0.181 \text{ d}^{-1}$$

$$N_1 = \frac{1000 \times 6.022 \times 10^{23} \text{ mol}^{-1}}{226 \text{ mol}^{-1}} = 2.66 \times 10^{24}$$

$$N_2 (0.181 \text{ d}^{-1}) = (2.66 \times 10^{24})(1.17 \times 10^{-6} \text{ d}^{-1})$$

$$N_2 = 1.72 \times 10^{19}$$

$$\text{Number of moles of } ^{222}\text{Rn} = \frac{1.72 \times 10^{19}}{6.022 \times 10^{23} \text{ mol}^{-1}} = 2.86 \times 10^{-5} \text{ mol}$$

$$\begin{aligned} \text{Volume of } ^{222}\text{Rn} &= 2.86 \times 10^{-5} \text{ mol} \times 25.0 \text{ L mol}^{-1} \\ &= 7.15 \times 10^{-4} \text{ L} \end{aligned}$$

$$(iii) \quad N_1 = N_0 e^{-\lambda t}$$

$$\text{Then } \frac{N_1}{N_2} = \frac{N_0 e^{-\lambda t_1}}{N_0 e^{-\lambda t_2}} = \frac{e^{-\lambda t_1}}{e^{-\lambda t_2}} = e^{\lambda(t_2 - t_1)}$$

$$\text{and } 10 = e^{\lambda(12.80 \text{ d})}$$

$$\lambda = \frac{\ln 10}{12.80 \text{ d}} = 0.181 \text{ d}^{-1}$$

$$t_{1/2} = \frac{0.693}{0.180 \text{ d}^{-1}} = 3.85 \text{ days}$$

- b) (i) On the reactant side there are 92 protons while on the product side there are 96 protons. There must be $4\beta^-$ and $2n$ on the product side.

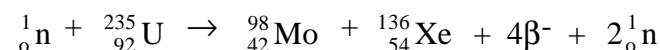

The elementary particles released : $4\beta^-$ and $2n$

- (ii) Input mass = $235.04393 \text{ u} + 1.00867 \text{ u} = 236.05260 \text{ u}$
 Output mass = $97.90551 \text{ u} + 135.90722 \text{ u} + (2)(1.00867 \text{ u})$
 = 235.83007 u

Masses of $4\beta^-$ are included in the atomic mass of products., so they do not appear in the output mass.

$$\Delta m = 236.05260 \text{ u} - 235.83007 \text{ u} = 0.22253 \text{ u}$$

$$\text{Energy} = (0.22253 \text{ u})(931.5 \text{ MeV u}^{-1}) = 207.3 \text{ MeV}$$

$$\text{Energy} = (207.3 \text{ MeV})(1.602 \times 10^{-13} \text{ J MeV}^{-1}) = 3.32 \times 10^{-11} \text{ J}$$

which is the energy per fission.

- (iii) Energy per gram = $\frac{6.022 \times 10^{23} \text{ mol}^{-1}}{235 \text{ g mol}^{-1}} \times 3.32 \times 10^{-11} \text{ J}$

$$= 8.51 \times 10^{10} \text{ J g}^{-1}$$

$$1 \text{ W} = 1 \text{ J s}^{-1}$$

$$1 \text{ kW-hour} = (1000 \text{ W})(3600 \text{ s}) = 3.60 \times 10^6 \text{ Ws}$$

$$= 3.60 \times 10^6 \text{ J}$$

$$\text{Power in kW-hour} = \frac{8.51 \times 10^{10} \text{ J}}{3.60 \times 10^6 \text{ J/kW-hour}}$$

$$= 2.36 \times 10^4 \text{ kW-hour}$$

Problem 4

- (i) Average initial rate ($\text{M}^{-1} \text{ min}^{-1}$)

$$0.00330/25.0 = 0.000132$$

$$0.00390/15.0 = 0.000260$$

$$0.00770/7.50 = 0.000103$$

When [B] is doubled, the rate is doubled, hence the reaction is first order in B. When [A] is doubled, the rate is quadrupled, hence the reaction is second order in A.

$$\text{Rate} = k[\text{A}]^2[\text{B}]$$

- (ii)

Entry	$k = \frac{\text{rate}}{[\text{A}]^2[\text{B}]}$
1	$\frac{0.000132}{(0.100)^2(0.0500)} = 0.264$
2	$\frac{0.00026}{(0.100)^2(0.0100)} = 0.260$
3	$\frac{0.000103}{(0.200)^2(0.100)} = 0.258$

The average of k is $0.261 \text{ L}^2\text{mol}^{-2}\text{min}^{-1} = 4.34 \times 10^{-3} \text{ L}^2\text{mol}^{-2}\text{s}^{-1}$.

Problem 5

- (i) Mechanism I : $\text{rate} = k_1[\text{OCl}^-][\text{I}^-]$

Mechanism II :

$$\text{rate} = k_2[\text{HOCl}][\text{I}^-] \quad (\text{slow step}) \quad (1)$$

steady-state Approximation

$$\text{rate} = 0 = k_1[\text{OCl}^-] - k_2[\text{HOCl}][\text{I}^-]$$

$$[\text{HOCl}] = k_1[\text{OCl}^-]/k_2[\text{I}^-] \quad (2)$$

$$(2) \text{ in (1) ; } \quad \text{rate} = \frac{d[\text{HOCl}]}{dt} = \frac{k_1 k_2 [\text{OCl}^-][\text{I}^-]}{k_2 [\text{I}^-]} = k_1 [\text{OCl}^-] \quad (3)$$

Mechanism III

$$\text{rate} = \frac{k_1 k_2 [\text{OCl}^-][\text{I}^-]}{k_{-1} [\text{OH}^-] + k_2 [\text{I}^-]} \quad (4)$$

if $k_2 \ll k_{-1}$

$$\text{rate} = \frac{k_1 k_2 [\text{OCl}^-][\text{I}^-]}{k_{-1} [\text{OH}^-]} \quad (5)$$

if $k_2 \gg k_{-1}$ $\text{rate} = k_1 [\text{OCl}^-]$ (6)

Therefore, Mechanism III is the most appropriate for observed kinetic behaviour when $k_2 \ll k_{-1}$

(ii) For Mechanism III

$$k = \frac{k_1 k_2}{k_{-1}}$$

$$E_a = E_{a1} + E_{a2} - E_{a-1}$$

$$A = \frac{A_1 A_2}{A_{-1}}$$

(iv) In a buffer solution, $[\text{OH}^-]$ is constant and $\text{rate} = k[\text{OCl}^-][\text{I}]$, therefore, the reaction is second order.

(iv) $K_w = [\text{H}_3\text{O}^+][\text{OH}^-]$; $[\text{OH}^-] = K_w / [\text{H}_3\text{O}^+]$

$$\text{rate} = \frac{k[\text{OCl}^-][\text{I}^-]}{[\text{OH}^-]} = \frac{k}{K_w} [\text{OCl}^-][\text{I}][\text{H}_3\text{O}^+]$$

(v) $\text{rate} = \frac{k}{K_w} \cdot [\text{OCl}^-][\text{I}][\text{H}_3\text{O}^+]$

$$\text{rate} = k_{\text{cat}}[\text{OCl}^-][\text{I}]$$

$$k_{\text{cat}} = \frac{k}{K_w} \cdot [\text{H}_3\text{O}^+]$$

$$\log k_{\text{cat}} = \log \frac{k}{K_w} - \text{pH}$$

Problem 6

a)

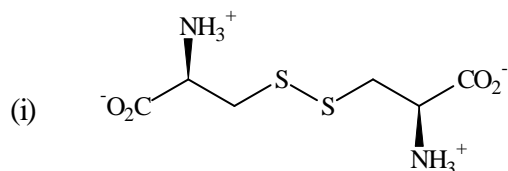

(ii) reducing agent

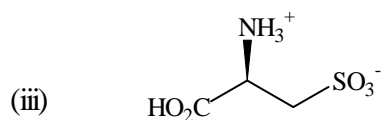

(iv) +4

- b) (i) Gly-Asp-Phe-Glu
 (ii) < 7

Problem 7

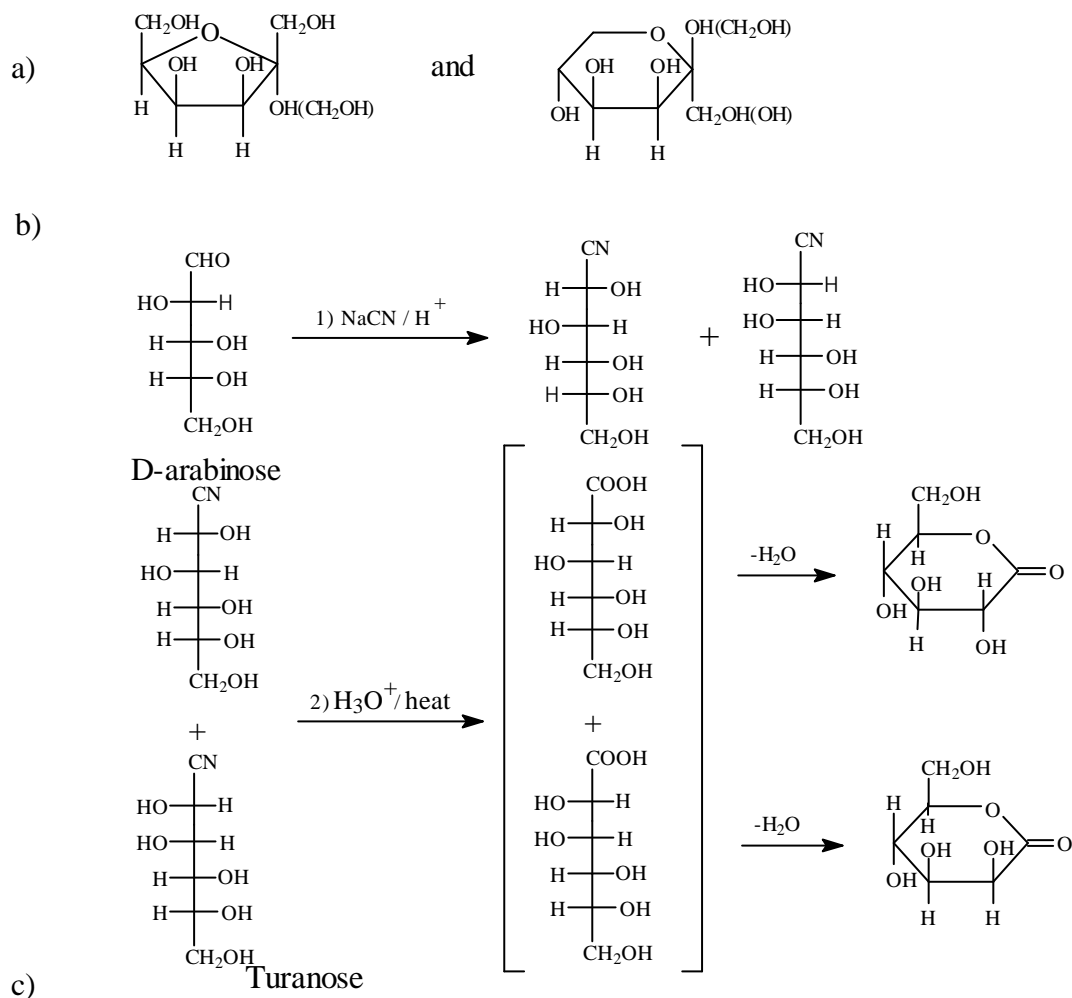

Problem 8

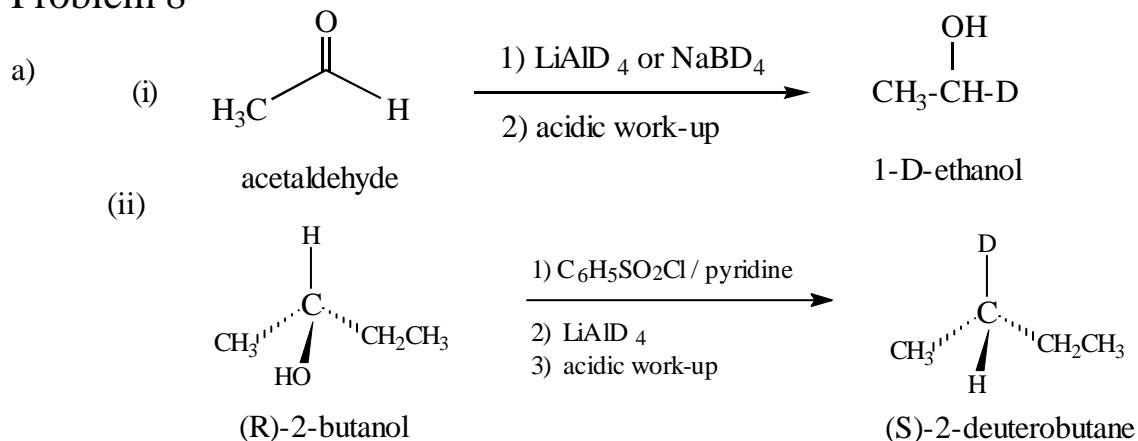

b)

- (i) Nucleophilic Aromatic Substitution
General mechanism:

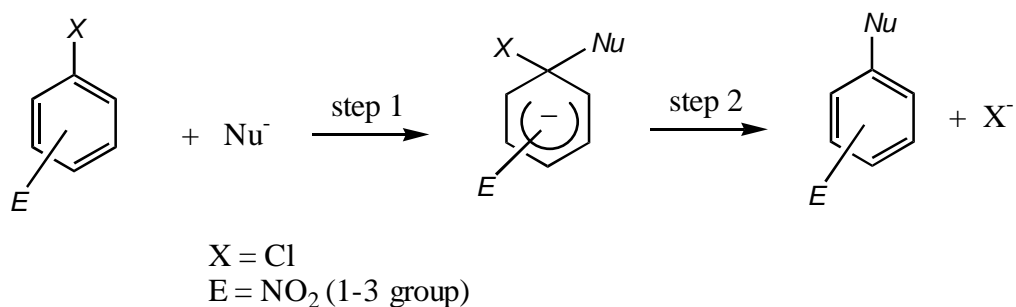

- (ii) slower

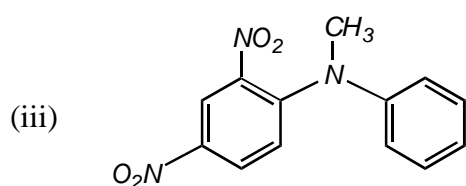

- (iv) According to mechanism in (i), step 1 is slower than step 2, and step 1 is the rate determining step.

Problem 9

a) (i)

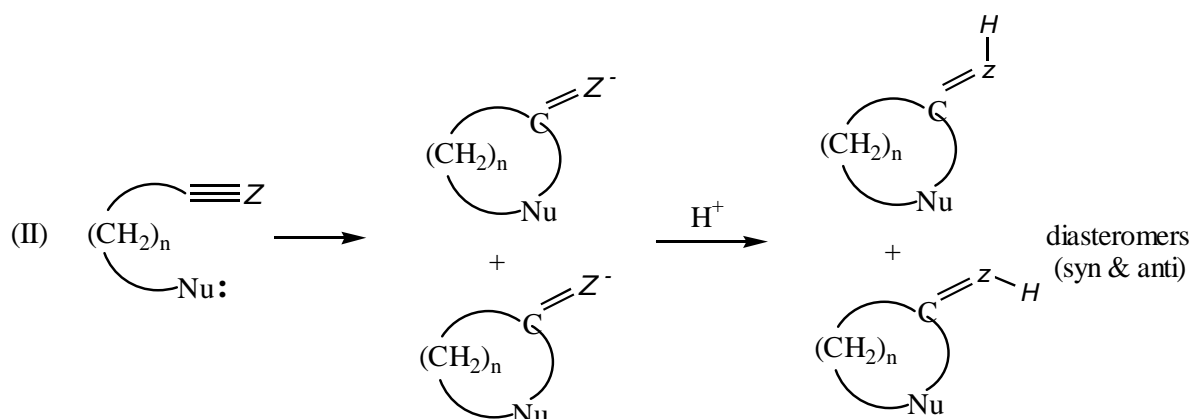
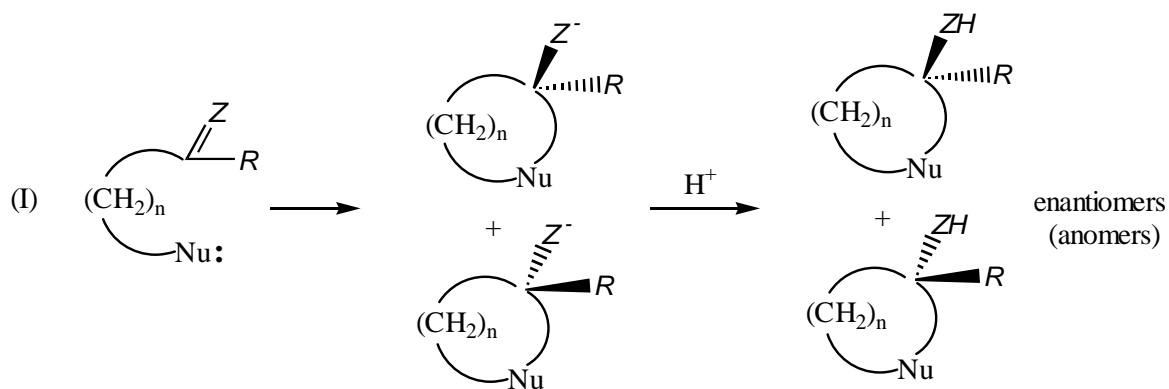

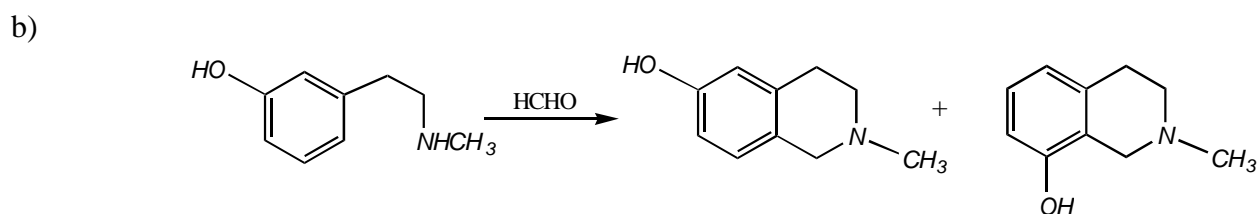
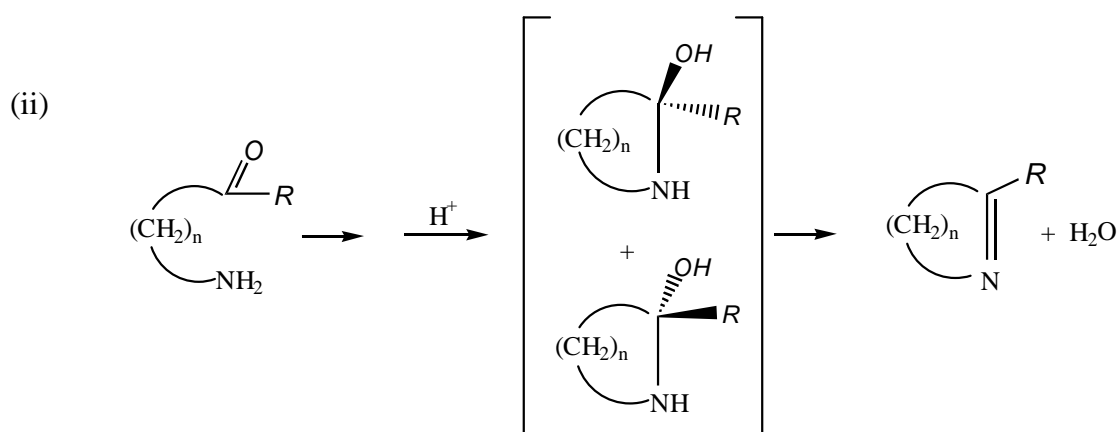

Problem 10

- a)
- (i) Pyridine is less basic than piperidine because the pair of electrons that gives pyridine its basicity occupies an sp^2 orbital; it is held more tightly and is less available for sharing with acids than the pair of electrons of piperidine, which occupies an sp^3 orbital.
 - (ii) Pyridine has a pair of electrons (in an sp^2 orbital) that is available for sharing with acid; pyrrole has not, and can accept a proton only at the expense of the aromatic character of the ring.
 - (iii) There are two reasons behind this observation. First, the nitrogen of aniline is bonded to an sp^2 -hybridized carbon atom of the aromatic ring, which is more electronegative than the sp^3 -hybridized carbon atom of cyclohexylamine. Second, the non-bonding electron can be delocalized to the aromatic ring. Resonance contributions indicate that it has decreased electro density at the nitrogen. Therefore, cyclohexylamine is more basic than aniline.

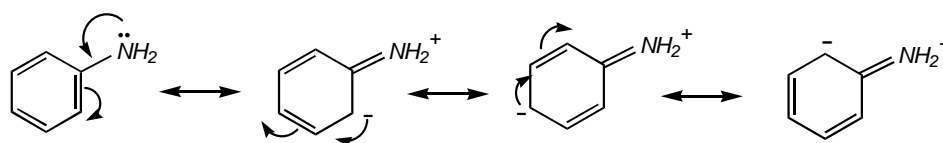

- (iv) Delocalization of lone pair of electrons of the NH_2 group into the ring is possible. This results in an increase electro density on the heterocyclic nitrogen atom, hence, an increase in basicity at this site.

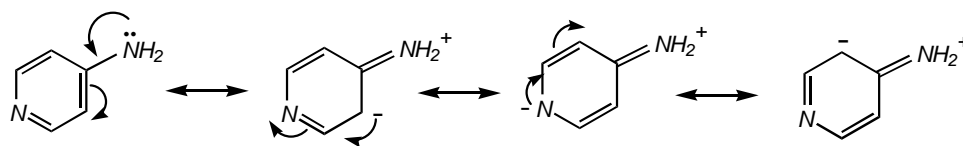

- (v) Piperidine is more basic than morpholine. The oxygen atom in morpholine is more electronegative than methylene group (at the same position) of piperidine so there is less electron density on nitrogen atom of morpholine than that of piperidine.

b)

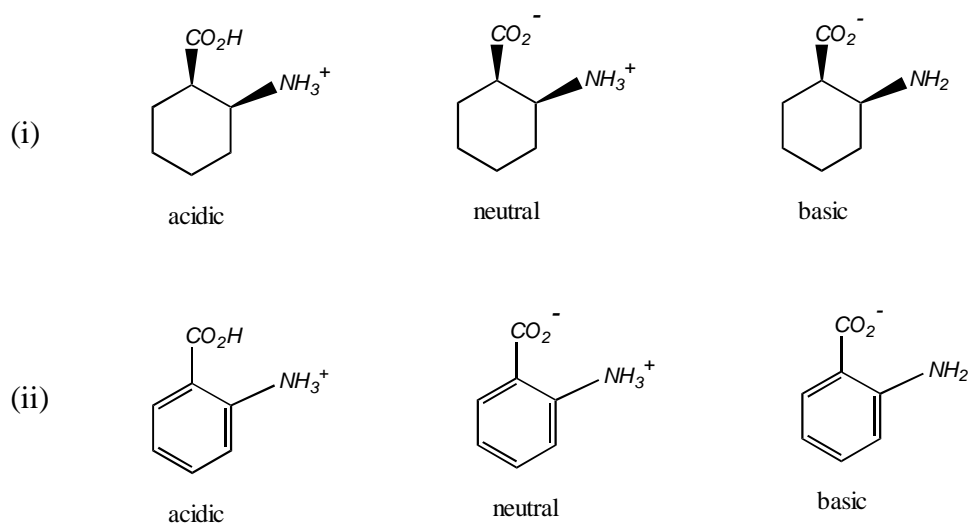

- (iii) isoelectric point = $(\text{pK}_{a1} + \text{pK}_{a2}) / 2 = 6.88$

Problem 11

a) Substitution of benzene by auxochromes, chromophores, or fused rings has different effects on the absorption spectrum.

- (i) Introduction of polar substituents such as $-\text{NH}_2$, $-\text{OH}$, OCH_3 cause marked spectral changes. The nonbonding electrons of the $-\text{OH}$ group can conjugate with the π system of the ring. Since the energy of the π^* system is lowered by delocalization over the entire conjugated system, the $n\text{-}\pi^*$ absorption occurs at longer wavelength than in benzene.
- (ii) Conversion of phenol to the phenolate anion makes an additional pair of nonbonding electrons available to the conjugated system, and both the

wavelengths and the intensities of the absorption bands are increased. A suspected phenolic group may be determined by comparison of the uv spectrum of the compound in neutral and in alkaline (pH 13) solution.

- (iii) Conversion of aniline to the anilinium cation involves attachment of a proton to the nonbonding electron pair, removing it from conjugation with the π

electrons of the ring. The absorption of this ion closely resemble those of benzene.

b)

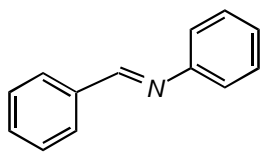

compound (I)

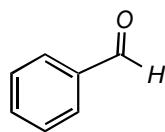

compound (II)

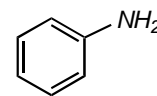

compound (III)

c)

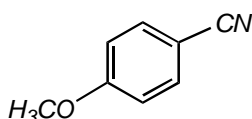

compound (IV)

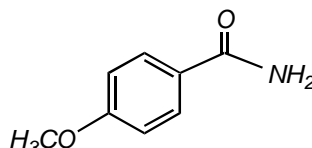

compound (V)

d) (i) allyl alcohol

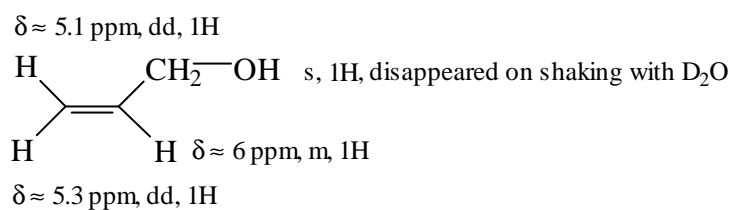

(ii) cyclopropanol

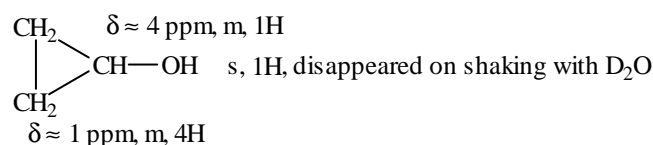

e)

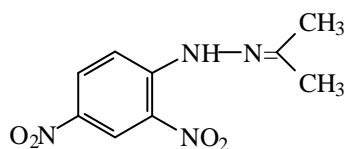

2,4-DNP-derivative

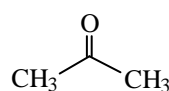

compound (VI)

Problem 12

(i) “Zeolite (I)”

Zeolite (I) (Si/Al = 1) contains more aluminium than zeolite (II) (Si/Al = 2), consequently it possess relatively higher number of exchangeable cation sites.

(ii) “Zeolites with high Si/Al”

In high silica zeolites, there is fewer number of acid sites than the lower one. In addition, electronegativity of Si is slightly higher than Al. Therefore, the more Si in the framework, the more electronegative the framework.

Accordingly, strength of an acid site in such framework is markedly stronger than that of the other.

(iii) “Zeolite containing Li”

Li is the smallest alkali cation. Its charge density is very high, so it would strongly interact with water.

Problem 13

a) (i) For A1 , there are three possible geometrical isomers.

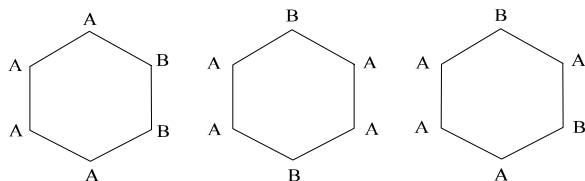

For A2 , there are also three possible geometrical isomers.

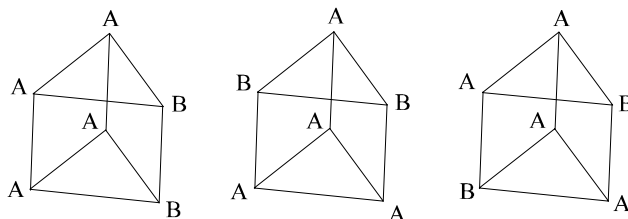

For A3 , only two geometrical isomers are possible.

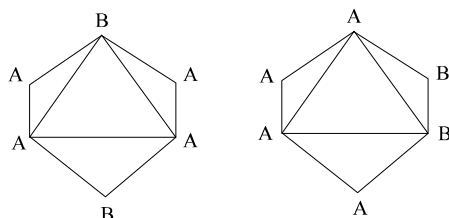

(ii) For A1 , there is only one geometrical isomer but no optical isomer.

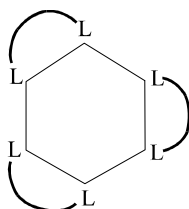

For A2 , there are two geometrical isomers with no optical isomers.

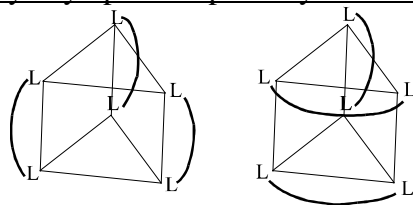

For A3 , two optical isomer existing in an enantiomeric pair.

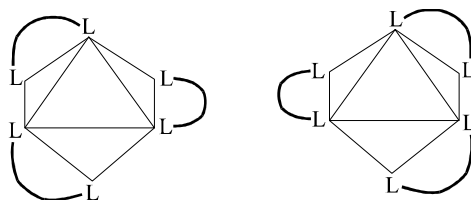

e)

(i) For the square planar geometry , there are three geometrical isomers , none has optical isomer. For the tetrahedral geometry there is only one geometrical arrangement which can exist as a pair of enantiomers.

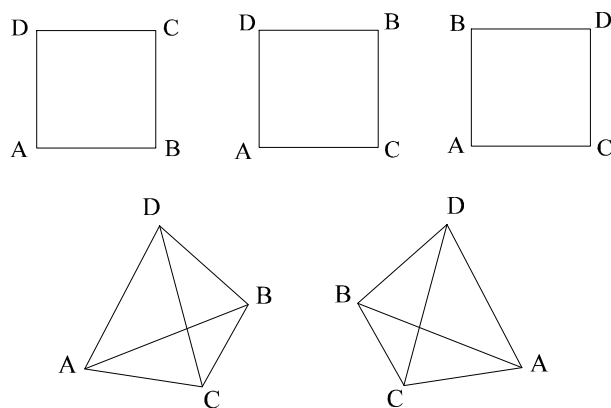

(ii) Both geometries can exist in one geometrical arrangement but no optical isomer.

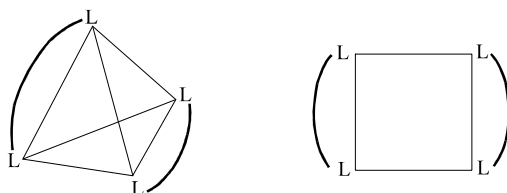

Problem 14

a) The electronic configuration of Co and Co^{3+} are as follows.

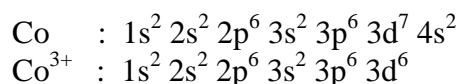

Co^{3+} ion is in octahedral crystal field. The electrons in d orbitals will be repelled by the field from the surrounding ligands. As a result , the $d_{x^2-y^2}$ and d_{z^2} orbitals, which point direct and

head-on toward the ligands will be repelled strongly and raised in energy. The rest of the d orbitals, d_{xy} , d_{xz} and d_{yz} , point into the space between the ligands, their energies are thus

relatively unaffected by the field. These two sets of d orbitals are designated as e_g and t_{2g} , respectively, and their energy difference is designated as Δ_0 or $10 Dq$. The crystal field splitting diagram is shown below.

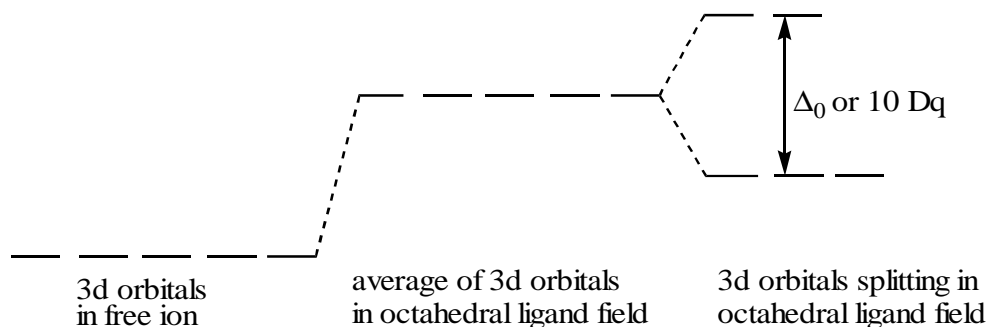

Different ligands split the d-orbital energies to different extents. Strong field ligands lead to a larger crystal field splitting energy (larger Δ_0); weak field ligands lead to a smaller splitting energy (smaller Δ_0). In the case of $[\text{CoF}_6]^{3-}$ ion, Δ_0 is smaller than that of $[\text{Co}(\text{en})_3]^{3+}$ ion. The splitting energy (Δ_0) and the orbital occupancy for these two complex ions are shown below.

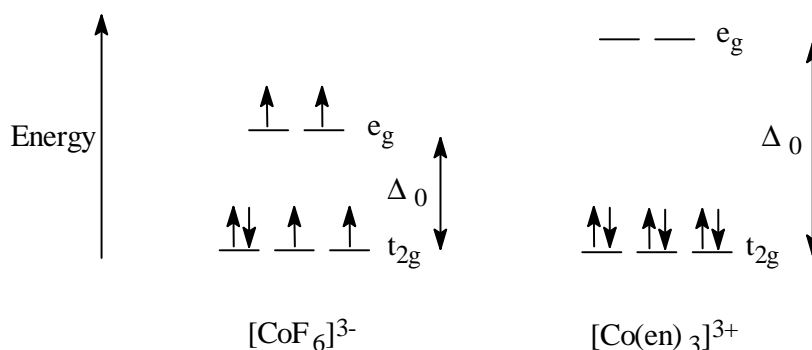

The complex ion $[\text{CoF}_6]^{3-}$ has all its six electrons distributed in the high spin configuration, as a result there are four unpaired electrons so it is paramagnetic. Its magnetic moment, μ , can be estimated from the 'spin-only' formula.

$$\mu = \sqrt{n(n+2)} \quad \text{B.M.}$$

where n is the number of unpaired electron. For $[\text{CoF}_6]^{3-}$, $n = 4$, therefore, $\mu = 4.89$ B.M.

While in $[\text{Co}(\text{en})_3]^{3+}$ ion all electrons are paired in the low spin configuration leading to a diamagnetic property. Since, for $[\text{Co}(\text{en})_3]^{3+}$, $n = 0$, therefore, $\mu = 0$ B.M.

The complex ion $[\text{CoF}_6]^{3-}$ has smaller Δ_0 , so it should absorb at longer λ .

b) The information contained in the table of relationship of wavelengths to colors in Problem 14 is useful in working out for the answers.

Table Rewritten formula and color of complexes.

Complexes	λ_{\max} , nm	Color
1. $[\text{Co}(\text{NH}_3)_6]\text{Cl}_3$ Hexaamminecobalt(III) chloride	475	Yellowish red
2. $[\text{Co}(\text{H}_2\text{O})(\text{NH}_3)_5](\text{NO}_3)_3$ Aquo pentaamminecobalt(III) nitrate	495	Red
3. $[\text{Co}(\text{CO}_3)(\text{NH}_3)_5]\text{NO}_3$ Carbonatopentaamminecobalt(III) nitrate	510	Red
4. $[\text{CoF}(\text{NH}_3)_5](\text{NO}_3)_2$ Fluoropentaamminecobalt(III) nitrate	515	Red
5. $[\text{CoCl}(\text{NH}_3)_5]\text{Cl}_2$ Chloropentaamminecobalt(III) chloride	534	Reddish violet
6. $[\text{CoBr}(\text{NH}_3)_5]\text{Br}_2$ Bromopentaamminecobalt(III) bromide	552	Violet

- (i) The IUPAC formula and the complex parts are shown in [] in the Table above.
- (ii) All these complexes can be written in the general form as $[\text{Co}(\text{NH}_3)_5\text{X}]^{(3-n)+}$ where $n = 0, 1$ or 2 depending on X groups. (X = NH_3 , H_2O , CO_3^{2-} , F^- , Cl^- , Br^-).

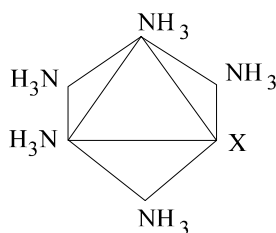

The different in λ_{\max} arise from the nature of different X groups which exert repulsion on the electrons of the d orbitals. The stronger the X group bonds to the central metal atom the stronger repulsion would be, rendering shift of λ_{\max} to the lower nm (higher energy) or larger Δ_0 as described in a). From the λ_{\max} shift, we can arrange the strength of X as follows.

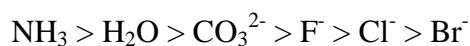

- c)
- (i) Referring to the wavelength absorbed and the color, free BBDAB absorbs at 428 nm (curve A), so the color of free BBDAB should be yellow. For Co-BBDAB complex (curve B) the absorption appears at 540 nm, so the color of the complex would be red-violet.
- (ii) The structure of 3,5-diBr-PAMB is rewritten to expose the lone pair electrons it possesses. The atoms with lone pair electrons are the potential sites that can bond to the metal atom. There are six sites altogether, but only some of them will be available to bonding. Of these, sites 1, 2, and 3 can bond

simultaneously leading to the chelate complex which is more stable compared with the other sites. The rest, sites 4, 5, and 6, can bond one at a

time as a monodentate ligand which is less stable. Sites 3 and 4 can be used together as a bidentate ligand, too, but is also less stable.

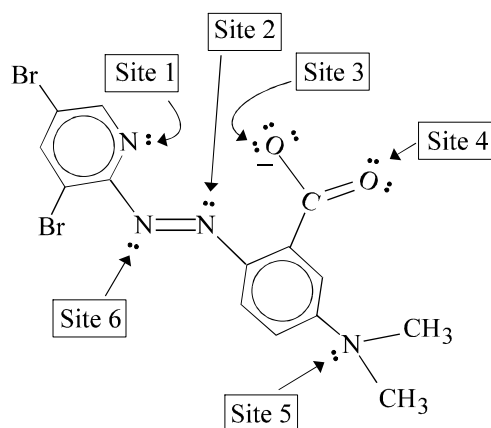

One form of the tentative complex is shown, by using sites 1, 2, and 3 to form a chelate complex. The complex consists of one metal atom and two molecules of 3,5-diBr-PAMB.

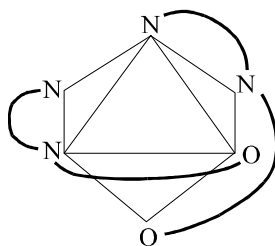

- (iii) The color of the complexes can be deduced as follows.
- Complex with reagent 1 : red violet
 - Complex with reagent 2 : blue green
 - Complex with reagent 3 : red violet
 - Complex with reagent 4 : red violet
 - Complex with reagent 5 : violet
 - Complex with reagent 6 : blue green

Problem 15

(i)	Cr	C	H	O	
Elemental composition	27.1	25.2	4.25	43.45	% by mass.
Atomic weight	52	12	1	16	
Number of moles	0.52	2.1	4.25	2.71	
Moles ratio	1	4.04	8.17	5.21	

From the mole ratio, the empirical formula would be $\text{CrC}_4\text{H}_8\text{O}_5$.

- (ii) From the empirical formula $\text{CrC}_4\text{H}_8\text{O}_5$, the compound is $[\text{Cr}(\text{CH}_3\text{COO})_2(\text{H}_2\text{O})]$. Therefore, the ligands are acetate groups. Since the

acetate group (CH_3COO) has a charge of -1, therefore, the oxidation state of Cr is 2^+ .

- (iii) Cr^{2+} ion is a d^4 system, i.e., having 4 electrons in the d orbitals. The distribution of four electrons should be in the high spin type due to the low strength of the ligands. This alone would make $[\text{Cr}(\text{CH}_3\text{COO})_2(\text{H}_2\text{O})]$ a paramagnetic species. However, from the experimental result this compound is, in fact, a diamagnetic compound. This is because the compound exists in the dimer form as shown.

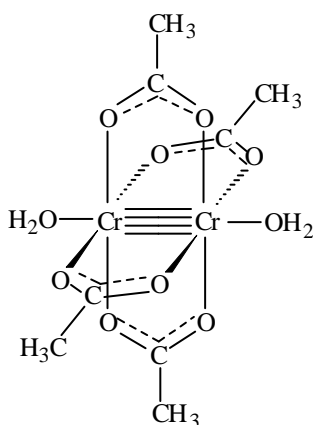

In this structure, the two Cr atoms form a quadruple bond consisting of one sigma, two pi, and one delta bonds, giving a total bond order of four. The formation of the quadruple bond requires that all the d orbital electrons must be paired up. Therefore, in term of magnetic property, the compound in the dimer form is diamagnetic.

Problem 16

- (i) P
 (ii) The simplest (or empirical) formula is CsCl .
 Number of Cs atom (at the center) = 1
 Number of Cl atoms = $(1/8) \times 8 = 1$
 $\text{Cs} : \text{Cl} = 1 : 1$
 (iii) Coordination number is 8.
 (iv) From the given information , the distance between the (100)plane can be calculated by using Bragg's Law.

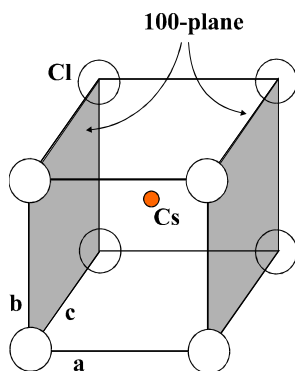

$$2d \sin \theta = n \lambda$$

$$\begin{aligned}
 d &= n\lambda / 2\sin \theta \\
 &= (1)(1.542) / (2)(0.1870) \\
 &= 4.123 \text{ \AA}
 \end{aligned}$$

That is the distance between (100)-planes, a , is 4.123 \AA .

$$\begin{aligned}
 \text{For the cubic cell, } a = b = c, \text{ therefore the volume of the cell} &= (4.123)^3 \\
 &= 70.09 \text{ \AA}^3.
 \end{aligned}$$

$$\begin{aligned}
 \text{(v) Density} &= w / v = Z.M / v \\
 &= (1 \times 168.36 \text{ g.mol}^{-1}) / [(6.02 \times 10^{23} \text{ mol}^{-1})(4.123 \times 10^{-8} \text{ cm})^3] \\
 &= 3.99 \text{ g.cm}^{-3}
 \end{aligned}$$

(vi) The diagonal plane of the unit cell can be shown below.

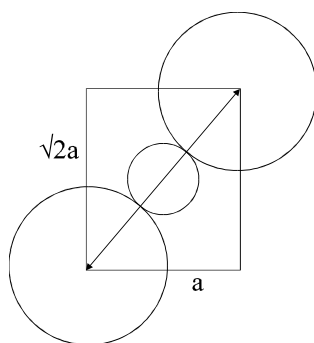

$$\begin{aligned}
 a^2 + (\sqrt{2}.a)^2 &= (2.r_{Cs} + 2.r_{Cl})^2 \\
 3.a^2 &= (2.r_{Cs} + 2(1.81))^2 \\
 \sqrt{3}.a &= 2.r_{Cs} + 3.62 \\
 r_{Cs} &= (\sqrt{3}.a - 3.62) / 2 \\
 &= (\sqrt{3} \times 4.123 - 3.62) / 2 \\
 &= 1.76 \text{ \AA}.
 \end{aligned}$$

Problem 17

a)

(i) Here, a buffer of H_3PO_4 and H_2PO_4^- is present

$$\begin{aligned}
 [\text{H}_3\text{PO}_4] &= [\text{H}_2\text{PO}_4^-] \\
 [\text{H}^+] &= K_1 \frac{[\text{H}_3\text{PO}_4]}{[\text{H}_2\text{PO}_4^-]} \\
 &= K_1 = 7.1 \times 10^{-3} \text{ M}
 \end{aligned}$$

$$\text{pH} = -\log(7.1 \times 10^{-3}) = 2.15$$

(ii) At the 2nd equivalent point, HPO_4^{2-} is present therefore

$$\begin{aligned}
 [\text{H}^+] &= (K_2 K_3)^{1/2} \\
 &= [(6.2 \times 10^{-8})(4.4 \times 10^{-13})]^{1/2} \\
 &= 1.7 \times 10^{-10} \text{ M}
 \end{aligned}$$

$$\text{pH} = -\log(1.7 \times 10^{-10}) = 9.77$$

(iii) HPO_4^{2-} ($K_3 = 4.4 \times 10^{-13}$) is not really a much stronger acid than H_2O

($K_w = 1.00 \times 10^{-14}$). Addition of strong base to HPO_4^{2-} solution is similar to addition of a strong base to water.

b) Since the formation constant for $\text{Ag}(\text{S}_2\text{O}_3)_2^{3-}$, $K_f = \frac{1}{K_d} = 1.667 \times 10^{13}$ is very large, therefore most of the added Ag^+ forms complex with $\text{S}_2\text{O}_3^{2-}$ and

$$[\text{Ag}(\text{S}_2\text{O}_3)_2^{3-}] = \frac{20 \text{ mmol}}{200 \text{ ml}} = 0.100 \text{ M}$$

$$\text{mmol of free } \text{S}_2\text{O}_3^{2-} = 530 - (2 \times 20) = 490 \text{ mmol}$$

$$[\text{S}_2\text{O}_3^{2-}] = \frac{490 \text{ mmol}}{200 \text{ ml}} = 2.450 \text{ M}$$

concentration of free Ag^+ calculated from K_d

$$K_d = \frac{[\text{Ag}^+][\text{S}_2\text{O}_3^{2-}]^2}{[\text{Ag}(\text{S}_2\text{O}_3)_2^{3-}]} = 6.0 \times 10^{-14}$$

$$[\text{Ag}^+] = \frac{6.0 \times 10^{-14} [\text{Ag}(\text{S}_2\text{O}_3)_2^{3-}]}{[\text{S}_2\text{O}_3^{2-}]^2} = \frac{6.0 \times 10^{-14} (0.100)}{(2.450)^2} = 1.0 \times 10^{-15}$$

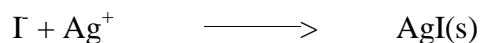

$$K_{sp} = [\text{Ag}^+][\text{I}^-] = 8.5 \times 10^{-17}$$

$$(1 \times 10^{-15})(\text{I}^-) = 8.5 \times 10^{-17}$$

$$[\text{I}^-] = \frac{8.5 \times 10^{-17}}{1.0 \times 10^{-15}} = 8.5 \times 10^{-2} \text{ M}$$

$$\text{mmol KI} = (8.5 \times 10^{-2})(200)$$

$$= 17.0 \text{ mmol}$$

Problem 18

a) **Ans:** *p*-nitro-di-Bolane is suitable indicator but not di-Bolane

For di-Bolane,

$$E_{\text{solution}} = E_{\text{dip}}^{\circ} + \frac{0.059}{2} \log \frac{[\text{In}_{\text{ox}}]}{[\text{In}_{\text{red}}]}$$

When $[\text{In}_{\text{ox}}] / [\text{In}_{\text{red}}] = 10$

$$E_{\text{solution}} = 0.76 + \frac{0.059}{2} \log 10 = 0.79$$

At 0.79 V, calculate $[\text{Fe}^{3+}] / [\text{Fe}^{2+}]$

$$E_{\text{solution}} = E_{\text{Fe}}^{\circ} - \frac{0.059}{1} \log \frac{[\text{Fe}^{2+}]}{[\text{Fe}^{3+}]}$$

$$0.79 = 0.77 + 0.059 \log \frac{[\text{Fe}^{3+}]}{[\text{Fe}^{2+}]}$$

$$\frac{[\text{Fe}^{3+}]}{[\text{Fe}^{2+}]} = 2.2$$

Di-Bolane is not suitable indicator because $[\text{Fe}^{3+}]$ is 2.2 times $[\text{Fe}^{2+}]$

For *p*-nitro-di-Bolane

$$E_{\text{solution}} = E_{\text{pn}}^{\circ} + \frac{0.059}{2} \log \frac{[\text{In}_{\text{ox}}]}{[\text{In}_{\text{red}}]}$$

When $[\text{In}_{\text{ox}}] / [\text{In}_{\text{red}}] = 10$

$$E_{\text{solution}} = 1.01 + \frac{0.059}{2} \log 10 = 1.04 \text{ V}$$

At 1.04 V, calculate $[\text{Fe}^{3+}] / [\text{Fe}^{2+}]$

$$E_{\text{solution}} = E_{\text{Fe}}^{\circ} + \frac{0.059}{1} \log \frac{[\text{Fe}^{2+}]}{[\text{Fe}^{3+}]}$$

$$1.04 = 0.77 + 0.059 \log \frac{[\text{Fe}^{3+}]}{[\text{Fe}^{2+}]}$$

$$\frac{[\text{Fe}^{3+}]}{[\text{Fe}^{2+}]} = 3.80 \times 10^4$$

b)

(i) Sodium oxalate, $\text{Na}_2\text{C}_2\text{O}_4$

(ii) $\text{MnO}_4^- (\text{aq}) + 8\text{H}^+ (\text{aq}) + 5\text{e}^- \longrightarrow \text{Mn}^{2+} (\text{aq}) + 4\text{H}_2\text{O} (\text{l})$

$E^{\circ} = +1.51 \text{ V}$

The Nernst equation is

$$E = E^{\circ} - \frac{RT}{5F} \ln \frac{[\text{Mn}^{2+}]}{[\text{MnO}_4^-] \cdot [\text{H}^+]^8}$$

or

$$E = 1.51 - \frac{(257 \times 10^{-3})}{5} \ln \frac{[\text{Mn}^{2+}]}{[\text{MnO}_4^-] \cdot [\text{H}^+]^8}$$

or

$$E = 1.51 - \frac{(59.2 \times 10^{-3})}{5} \log \frac{[\text{Mn}^{2+}]}{[\text{MnO}_4^-] \cdot [\text{H}^+]^8}$$

- (iii) One mole of electron is required for one mole of the gaseous product.
Half reaction is $\text{C}_2\text{O}_4^{2-}(\text{aq}) \longrightarrow 2\text{CO}_2(\text{g}) + 2\text{e}^-$
- (iv) Ten moles of electron is involved in overall reaction.
- (v) The overall or net reaction of compound A and potassium permanganate.

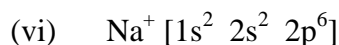
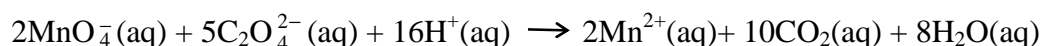

(vii) Stoichiometric ratio = $\frac{\text{mol KMnO}_4}{\text{mol Na}_2\text{C}_2\text{O}_4} = \frac{2}{5}$

Therefore, the molarity of the potassium permanganate solution is 0.00146 M.

- (viii) No, since $E^\circ(\text{M}^+, \text{M}) = +1.69 \text{ V}$ is higher than the standard potential of potassium permanganate.
- (ix) The biological standard potential (at pH 7) of the half reaction is 1.69 V.

Problem 19

a)

(i) From

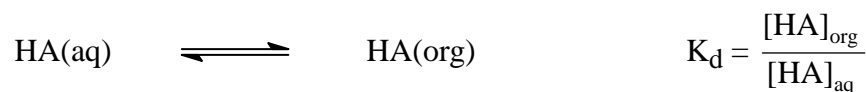
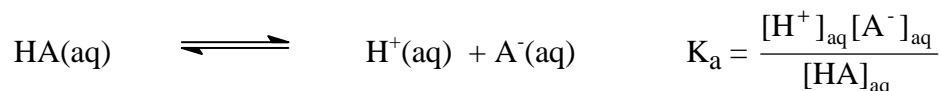

Distribution ratio (D) can be estimated as

$$\begin{aligned} D &= \frac{[\text{HA}]_{\text{org}}}{[\text{HA}]_{\text{aq}} + [\text{A}^-]_{\text{aq}}} \\ &= \frac{[\text{HA}]_{\text{org}} / [\text{HA}]_{\text{aq}}}{[\text{HA}]_{\text{aq}} / [\text{HA}]_{\text{aq}} + [\text{A}^-]_{\text{aq}} / [\text{HA}]_{\text{aq}}} \\ &= \frac{K_d}{1 + K_a / [\text{H}^+]} \end{aligned}$$

(ii) From answer (i)

$$\log D = \log K_d - \log (1+K_a/[H^+])$$

at low pH: $[H^+] \gg K_a$

$$\log D = \log K_d = \text{constant}$$

$$D = K_d; K_d = 5.190 \text{ (average of 5.200, 5.180 and 5.190)}$$

at high pH: $[H^+] \ll K_a$

therefore

$$\log D = \log K_d - \log K_a/[H^+]$$

$$\log D = \log K_d - \log K_a - \text{pH}$$

$$\text{Therefore, } \log K_d - \log K_a = 6.70$$

$$K_a = 1.02 \times 10^{-6}$$

b)

$$\begin{aligned} \text{(i) Resolution, } R_s &= 2[(t_R)_B - (t_R)_A] / (W_A + W_B) \\ &= 2[(17.63-16.40)] / (1.11+1.21) \\ &= 1.06 \end{aligned}$$

$$\begin{aligned} \text{(ii) The number of theoretical plates, } N &= 16(t_R/W)^2 \\ \text{For the first peak, } N &= 16 (16.40/1.11)^2 = 3493 \\ \text{for the second peak, } N &= 16 (17.63/1.21)^2 = 3397 \end{aligned}$$

$$\text{The average number of plates, } N_{av} = (3493+3397)/2 = 3495 \sim 3.4 \times 10^3$$

$$\begin{aligned} \text{(iii) The plate height (H) can be calculated from } L/N \\ \text{when } L = \text{column length and } N = \text{number of theoretical plates.} \\ H = 30.0 \text{ cm}/3445 = 8.7 \times 10^{-3} \text{ cm} \end{aligned}$$

$$\text{(iv) } N = 16 R_s^2 \left(\frac{\alpha}{\alpha - 1} \right)^2 \left(\frac{1 + k'_B}{k'_B} \right)^2$$

The capacity factor (k') and the selectivity factor (α) do not change with N or L , therefore

$$(R_s)_1 / (R_s)_2 = \sqrt{N_1} / \sqrt{N_2}$$

where subscripts 1 and 2 refer to the original and the longer columns, respectively.

$$\begin{aligned} 1.06/1.5 &= \sqrt{3.4 \times 10^3} / \sqrt{N_2} \\ N_2 &= 6.9 \times 10^3 \\ L &= N.H = 60 \text{ cm} \end{aligned}$$

Problem 20

a) For peaks in the molecular ion cluster, three peaks are expected from two chlorine atoms. The intensities can be calculated from $(a+b)^n$

where a = relative abundance of the light isotope (^{35}Cl)

b = relative abundance of the heavy isotope (^{37}Cl)

n = number of halogen atoms present.

31st International Chemistry Olympiad Preparatory Problems

Since the relative abundance of $^{35}\text{Cl} = 75.77$ and that of $^{37}\text{Cl} = 24.23$, it can be assumed then that their relative abundances are $^{35}\text{Cl} = 3$ and $^{37}\text{Cl} = 1$ for purpose of convenience.

$$(i) \quad \text{Relative intensities of the peaks at } m/z \text{ 84, 86 and 88} = a^2 + 2ab + b^2 \\ = 3^2 + 2 \times 3 \times 1 + 1^2$$

That is, the relative intensities for m/z 84:86:88 = 9:6:1

(ii) As for the peaks at m/z 49 and 51, corresponding to the loss of one chlorine atom from the molecular ion, the two peaks are due to $\text{CH}_2 \text{ } ^{35}\text{Cl}^+$ and $\text{CH}_2 \text{ } ^{37}\text{Cl}^+$, respectively.

$$\text{Relative intensity of the peak at } m/z \text{ 49 and 51} = a + b \\ = 3 + 1$$

That is, the relative intensities for m/z 49:51 = 3:1

b) In terms of the relative abundance, $^{79}\text{Br} : ^{81}\text{Br} = 50.69 : 49.31 \approx 1:1$.
Relative intensities of the isotopic peaks can be calculated from $(a+b)^n$
where a = relative intensity of $^{79}\text{Br} = 1$
 b = relative intensity of $^{81}\text{Br} = 1$
 n = number of halogen atoms present = 3

$$\text{Relative intensities} = a^3 + 3a^2b + 3ab^2 + b^3$$

$$M : (M+2) : (M+4) : (M+6) = 1^3 : 3 \times 1^2 \times 1 : 3 \times 1 \times 1^2 : 1^3 = 1:3:3:1$$

Problem 21

(i) From Beer's Law, $A = \epsilon bc$

$$\epsilon_X^{440} = \frac{0.096}{1.00 \times 8.00 \times 10^{-5}} = 1.2 \times 10^3 \quad \text{cm}^{-1} \text{ mol}^{-1} \text{ L}$$

$$\epsilon_X^{660} = \frac{0.373}{1.00 \times 8.00 \times 10^{-5}} = 4.67 \times 10^3 \text{ cm}^{-1} \text{ mol}^{-1} \text{ L}$$

$$\epsilon_Y^{440} = \frac{0.600}{1.00 \times 2.00 \times 10^{-4}} = 3.00 \times 10^3 \quad \text{cm}^{-1} \text{ mol}^{-1} \text{ L}$$

$$\epsilon_Y^{660} = \frac{0.030}{1.00 \times 2.00 \times 10^{-4}} = 1.50 \times 10^2 \quad \text{cm}^{-1} \text{ mol}^{-1} \text{ L}$$

(ii) At 520 nm

$$\text{Absorbance} = A_X + A_Y \\ = \frac{3.00 \times 10^{-5}}{8.00 \times 10^{-5}} \times 0.113 + \frac{5.00 \times 10^{-4}}{2.00 \times 10^{-4}} \times 0.433 \\ = 1.125$$

At 600 nm

$$\text{Absorbance} = A_X + A_Y \\ = \frac{3.00 \times 10^{-5}}{8.00 \times 10^{-5}} \times 0.264 + \frac{5.00 \times 10^{-4}}{2.00 \times 10^{-4}} \times 0.100 \\ = 0.349$$

(iii) At 440 nm

$$0.400 = 1.2 \times 10^3 C_X + 3.0 \times 10^3 C_Y$$

At 660 nm

$$0.500 = 4.67 \times 10^3 C_X + 1.5 \times 10^2 C_Y$$

The above two equations can be solved for C_X and C_Y

$$C_X = 1.04 \times 10^{-4} \text{ M}$$

$$C_Y = 9.17 \times 10^{-5} \text{ M}$$